

Deutsches Institut für Bautechnik

Anstalt des öffentlichen Rechts

Kolonnenstr. 30 L
10829 Berlin
Germany

Tel.: +49(0)30 787 30 0
Fax: +49(0)30 787 30 320
E-mail: dibt@dibt.de
Internet: www.dibt.de

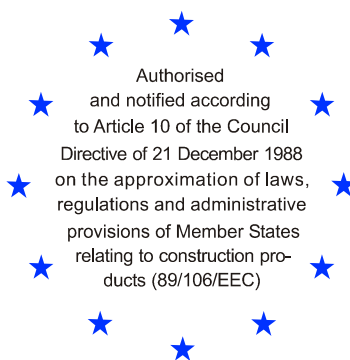

DIBt

Mitglied der EOTA
Member of EOTA

European Technical Approval ETA-02/0030

English translation prepared by DIBt - Original version in German language

Handelsbezeichnung <i>Trade name</i>	MKT Schwerlastanker SZ <i>MKT Highload Anchor SZ</i>
Zulassungsinhaber <i>Holder of approval</i>	MKT Metall-Kunststoff-Technik GmbH & Co. KG Auf dem Immel 2 67685 Weilerbach
Zulassungsgegenstand und Verwendungszweck	Kraftkontrolliert spreizender Dübel aus galvanisch verzinktem Stahl, in den Größen M 6, M 8, M 10, M 12 und M 16 zur Verankerung im Beton
<i>Generic type and use of construction product</i>	<i>Torque controlled expansion anchor made of galvanised steel of sizes M 6, M 8, M 10, M 12 and M 16 for use in concrete</i>
Geltungsdauer: <i>Validity:</i>	vom <i>from</i> 13 December 2005 bis <i>to</i> 25 March 2008
Herstellwerk <i>Manufacturing plant</i>	MKT Metall-Kunststoff-Technik GmbH & Co. KG Auf dem Immel 2 67685 Weilerbach

Diese Zulassung umfasst
This Approval contains

15 Seiten einschließlich 8 Anhänge
15 pages including 8 annexes

Diese Zulassung ersetzt
This Approval replaces

ETA-02/0030 mit Geltungsdauer vom 20.09.2005 bis 25.03.2008
ETA-02/0030 with validity from 20.09.2005 to 25.03.2008



Europäische Organisation für Technische Zulassungen
European Organisation for Technical Approvals

I LEGAL BASES AND GENERAL CONDITIONS

- 1 This European Technical Approval is issued by Deutsches Institut für Bautechnik in accordance with:
 - Council Directive 89/106/EEC of 21 December 1988 on the approximation of laws, regulations and administrative provisions of Member States relating to construction products¹, modified by Council Directive 93/68/EEC² and Regulation (EC) N° 1882/2003 of the European Parliament and of the Council³;
 - Gesetz über das In-Verkehr-Bringen von und den freien Warenverkehr mit Bauprodukten zur Umsetzung der Richtlinie 89/106/EWG des Rates vom 21. Dezember 1988 zur Angleichung der Rechts- und Verwaltungsvorschriften der Mitgliedstaaten über Bauprodukte und anderer Rechtsakte der Europäischen Gemeinschaften (Bauproduktengesetz - BauPG) vom 28. April 1998⁴, zuletzt geändert durch Gesetz vom ('last amended by law on') 06.01.2004⁵;
 - Common Procedural Rules for Requesting, Preparing and the Granting of European Technical Approvals set out in the Annex to Commission Decision 94/23/EC⁶;
 - Guideline for European Technical Approval of "Metal anchors for use in concrete - Part 2: Torque controlled expansion anchors ", ETAG 001-02.
- 2 Deutsches Institut für Bautechnik is authorized to check whether the provisions of this European Technical Approval are met. Checking may take place in the manufacturing plant. Nevertheless, the responsibility for the conformity of the products to the European Technical Approval and for their fitness for the intended use remains with the holder of the European Technical Approval.
- 3 This European Technical Approval is not to be transferred to manufacturers or agents of manufacturers other than those indicated on page 1, or manufacturing plants other than those indicated on page 1 of this European Technical Approval.
- 4 This European Technical Approval may be withdrawn by Deutsches Institut für Bautechnik, in particular pursuant to information by the Commission according to Article 5(1) of Council Directive 89/106/EEC.
- 5 Reproduction of this European Technical Approval including transmission by electronic means shall be in full. However, partial reproduction can be made with the written consent of Deutsches Institut für Bautechnik. In this case partial reproduction has to be designated as such. Texts and drawings of advertising brochures shall not contradict or misuse the European Technical Approval.
- 6 The European Technical Approval is issued by the approval body in its official language. This version corresponds fully to the version circulated in EOTA. Translations into other languages have to be designated as such.

1 Official Journal of the European Communities N° L 40, 11.2.1989, p. 12

2 Official Journal of the European Communities N° L 220, 30.8.1993, p. 1

3 Official Journal of the European Union N° L 284, 31.10.2003, p. 25

4 Bundesgesetzblatt I, p. 812

5 Bundesgesetzblatt I, p.2, 15

6 Official Journal of the European Communities N° L 17, 20.1.1994, p. 34

II SPECIFIC CONDITIONS OF THE EUROPEAN TECHNICAL APPROVAL

1 Definition of the construction product and intended use

1.1 Definition of the product

The MKT Highload Anchor SZ (type SZ-B, SZ-S and SZ-SK) in the range of M6, M8, M10, M12 and M16 is an anchor made of galvanised steel which is placed into a drilled hole and anchored by torque-controlled expansion.

An illustration of the product and intended use is given in Annex 1.

1.2 Intended use

The anchor is intended to be used for anchorages for which requirements for mechanical resistance and stability and safety in use in the sense of the Essential Requirements 1 and 4 of Council Directive 89/106 EEC shall be fulfilled and failure of anchorages made with these products would cause risk to human life and/or lead to considerable economic consequences.

The anchor may be used for anchorages with requirements related to resistance to fire.

The anchor is to be used only for anchorages subject to static or quasi-static loading in reinforced or unreinforced normal weight concrete of strength classes C20/25 at minimum and C50/60 at most according to EN 206: 2000-12. It may be anchored in cracked and non-cracked concrete.

The anchor may only be used in structures subject to dry internal conditions.

The provisions made in this European Technical Approval are based on an assumed working life of the anchor of 50 years. The indications given on the working life cannot be interpreted as a guarantee given by the producer, but are to be regarded only as a means for choosing the right products in relation to the expected economically reasonable working life of the works.

2 Characteristics of the product and methods of verification

2.1 Characteristics of the product

The anchor corresponds to the drawings and provisions given in Annexes 2 and 3. The characteristic material values, dimensions and tolerances of the anchor not given in Annexes 2 and 3 shall correspond to the respective values laid down in the technical documentation⁷ of this European Technical Approval.

Regarding the requirements concerning safety in case of fire it is assumed that the anchor meets the requirements of class A1 in relation to reaction to fire in accordance with the stipulations of the Commission decision 96/603/EC, amended by 2000/605/EC.

The characteristic values for the design of anchorages are given in Annexes 4 to 6.

The characteristic values for the design of anchorages regarding resistance to fire are given in Annexes 7 and 8. They are valid for use in a system that is required to provide a specific fire resistance class.

Each expansion sleeve is marked with the identifying mark of the producer, the trade name and the size of the thread, the distance sleeve is marked with the outer diameter of the anchor and the maximum thickness of fixture according to Annex 2.

The anchor shall only be packaged and supplied as a complete unit.

⁷ The technical documentation of this European Technical Approval is deposited at the Deutsches Institut für Bautechnik and, as far as relevant for the tasks of the approved bodies involved in the attestation of conformity procedure, is handed over to the approved bodies.

2.2 Methods of verification

The assessment of fitness of the anchor for the intended use in relation to the requirements for mechanical resistance and stability and safety in use in the sense of the Essential Requirements 1 and 4 has been made in accordance with the "Guideline for European Technical Approval of Metal Anchors for Use in Concrete", Part 1 "Anchors in general" and Part 2 "Torque-controlled expansion anchors", on the basis of Option 1.

The assessment of the anchor for the intended use in relation to the requirements for resistance to fire has been made in accordance with the Technical Report N°020 "Evaluation of anchorages in concrete concerning resistance to fire".

In addition to the specific clauses relating to dangerous substances contained in this European Technical Approval, there may be other requirements applicable to the products falling within its scope (e.g. transposed European legislation and national laws, regulations and administrative provisions). In order to meet the provisions of the Construction Products Directive, these requirements need also to be complied with, when and where they apply.

3 Evaluation and attestation of conformity and CE marking

3.1 System of attestation of conformity

According to the decision 96/582/EG of the European Commission⁸ the system 2(i) (referred to as system 1) of attestation of conformity applies.

System 1: Certification of the conformity of the product by an approved certification body on the basis of:

(a) Tasks for the manufacturer:

- (1) factory production control;
- (2) further testing of samples taken at the factory by the manufacturer in accordance with a prescribed test plan;

(b) Tasks for the approved body:

- (3) initial type-testing of the product;
- (4) initial inspection of factory and of factory production control;
- (5) continuous surveillance, assessment and approval of factory production control.

3.2 Responsibilities

3.2.1 Tasks of the manufacturer

3.2.1.1 Factory production control

The manufacturer shall exercise permanent internal control of production. All the elements, requirements and provisions adopted by the manufacturer shall be documented in a systematic manner in the form of written policies and procedures, including records of results performed. This production control system shall insure that the product is in conformity with this European Technical Approval.

The manufacturer may only use initial/ raw/ constituent materials stated in the technical documentation of this European Technical Approval.

The factory production control shall be in accordance with the control plan of November 2002 which is part of the technical documentation of this European Technical Approval. The control plan is laid down in the context of the factory production control system operated by the manufacturer and deposited at Deutsches Institut für Bautechnik⁹.

The results of factory production control shall be recorded and evaluated in accordance with the provisions of the control plan.

⁸ Official Journal of the European Communities L 254 of 8.10.1996.

⁹ The control plan is a confidential part of the documentation of the European Technical Approval, but not published together with the ETA and only handed over to the approved body involved in the procedure of attestation of conformity.
See section 3.2.2.

3.2.1.2 Other tasks of manufacturer

The manufacturer shall, on the basis of a contract, involve a body which is approved for the tasks referred to in section 3.1 in the field of anchors in order to undertake the actions laid down in section 3.2.2. For this purpose, the control plan referred to in sections 3.2.1.1 and 3.2.2 shall be handed over by the manufacturer to the approved body involved.

The manufacturer shall make a declaration of conformity, stating that the construction product is in conformity with the provisions of this European Technical Approval.

3.2.2 Tasks of approved bodies

The approved body shall perform the

- initial type-testing of the product ,
 - initial inspection of factory and of factory production control,
 - continuous surveillance, assessment and approval of factory production control,
- in accordance with the provisions laid down in the control plan.

The approved body shall retain the essential points of its actions referred to above and state the results obtained and conclusions drawn in a written report.

The approved certification body involved by the manufacturer shall issue an EC certificate of conformity of the product stating the conformity with the provisions of this European Technical Approval.

In cases where the provisions of the European Technical Approval and its control plan are no longer fulfilled the certification body shall withdraw the certificate of conformity and inform Deutsches Institut für Bautechnik without delay.

3.3 CE marking

The CE marking shall be affixed on each packaging of the anchor. The letters "CE" shall be followed by the identification number of the approved certification body, where relevant, and be accompanied by the following additional information:

- the name and address of the producer (legal entity responsible for the manufacturer),
- the last two digits of the year in which the CE marking was affixed,
- the number of the EC certificate of conformity for the product,
- the number of the European Technical Approval,
- the number of the guideline for European Technical Approval
- use category (ETAG 001-1 Option 1),
- size.

4 Assumptions under which the fitness of the product for the intended use was favourably assessed

4.1 Manufacturing

The European Technical Approval is issued for the product on the basis of agreed data/information, deposited with Deutsches Institut für Bautechnik, which identifies the product that has been assessed and judged. Changes to the product or production process, which could result in this deposited data/information being incorrect, should be notified to Deutsches Institut für Bautechnik before the changes are introduced. Deutsches Institut für Bautechnik will decide whether or not such changes affect the ETA and consequently the validity of the CE marking on the basis of the ETA and if so whether further assessment or alterations to the ETA shall be necessary.

4.2 Installation

4.2.1 Design of anchorages

The fitness of the anchor for the intended use is given under the following conditions:

The anchorages are designed in accordance with the "Guideline for European Technical Approval of Metal Anchors for Use in Concrete", Annex C, Method A, for torque controlled expansion anchors under the responsibility of an engineer experienced in anchorages and concrete work.

Verifiable calculation notes and drawings are taking account of the loads to be anchored.

The position of the anchor is indicated on the design drawings (e.g. position of the anchor relative to reinforcement or to supports).

The design of anchorages under fire exposure has to consider the conditions given in the Technical Report N°020 "Evaluation of anchorages in concrete concerning resistance to fire". The relevant characteristic anchor values are given in Annexes 7 and 8. The design method covers anchors with a fire attack from one side only. If the fire attack is from more than one side, the design method may be taken only, if the edge distance of the anchor is $c \geq 300$ mm.

4.2.2 Installation of anchors

The fitness for use of the anchor can only be assumed if the anchor is installed as follows:

- Anchor installation carried out by appropriately qualified personnel and under the supervision of the person responsible for technical matters of the site,
- Use of the anchor only as supplied by the manufacturer without exchanging the components of an anchor,
- Anchor installation in accordance with the manufacturer's specifications and drawings and using the appropriate tools,
- Checks before placing the anchor to ensure that the strength class of the concrete in which the anchor is to be placed is in the range given and is not lower than that of the concrete to which the characteristic loads apply,
- Check of concrete being well compacted, e.g. without significant voids,
- Edge distances and spacings not less than the specified values without minus tolerances,
- Positioning of the drill holes without damaging the reinforcement,
- In case of aborted hole: new drilling at a minimum distance away of twice the depth of the aborted hole or smaller distance if the aborted drill hole is filled with high strength mortar and if under shear or oblique tension load it is not in the direction of load application,
- Cleaning of the hole of drilling dust,
- Anchor installation such that the effective anchorage depth is complied with. This compliance is ensured when the embedment mark of the anchor does no more exceed the concrete surface,
- Application of the torque moment given in Annex 4 using a calibrated torque wrench.

4.2.3 Responsibility of the manufacturer

The manufacturer is responsible to ensure that the information on the specific conditions according to 1 and 2 including Annexes referred to and 4.2.1 and 4.2.2 is given to those who are concerned. This information may be made by reproduction of the respective parts of the European Technical Approval. In addition all installation data shall be shown clearly on the package and/or on an enclosed instruction sheet, preferably using illustration(s).

The minimum data required are:

- Diameter of drill bit,
- Thread diameter,
- Maximum thickness of the fixture,

- Minimum effective anchorage depth,
- Minimum hole depth,
- Torque moment,
- Information on the installation procedure, including cleaning of the hole, preferably by means of an illustration,
- Reference to any special installation equipment needed,
- Identification of the manufacturing batch.

All data shall be presented in a clear and explicit form.

Dipl.-Ing. E. Jasch

Beglaubigt:
Lange

Anchor type SZ-B with threaded bolt

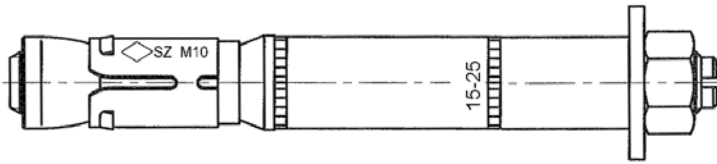

SZ-B (M6-M16)

Anchor type SZ-S with hexagon head screw

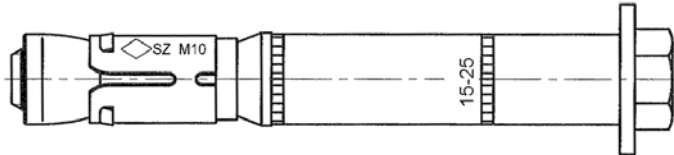

SZ-S (M6-M16)

Anchor type SZ-SK with countersunk washer and countersunk head screw

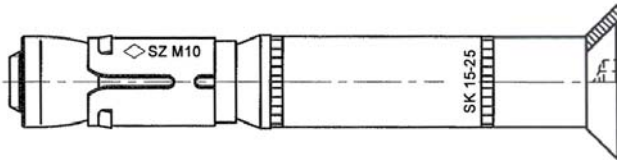

SZ-SK (M6-M12)

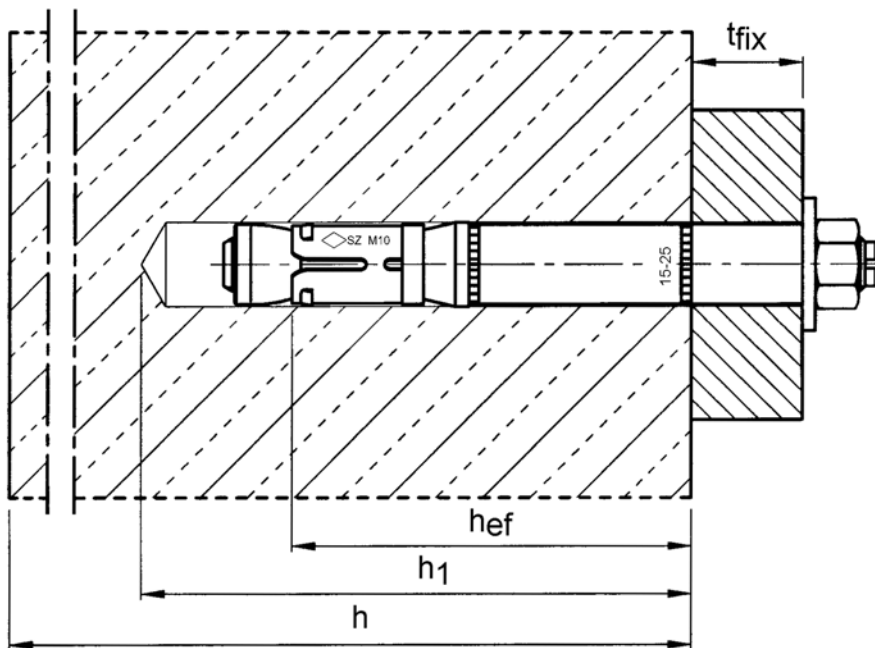

MKT Highload Anchor SZ

Product and intended use

Annex 1

of European
Technical Approval

ETA-02/0030

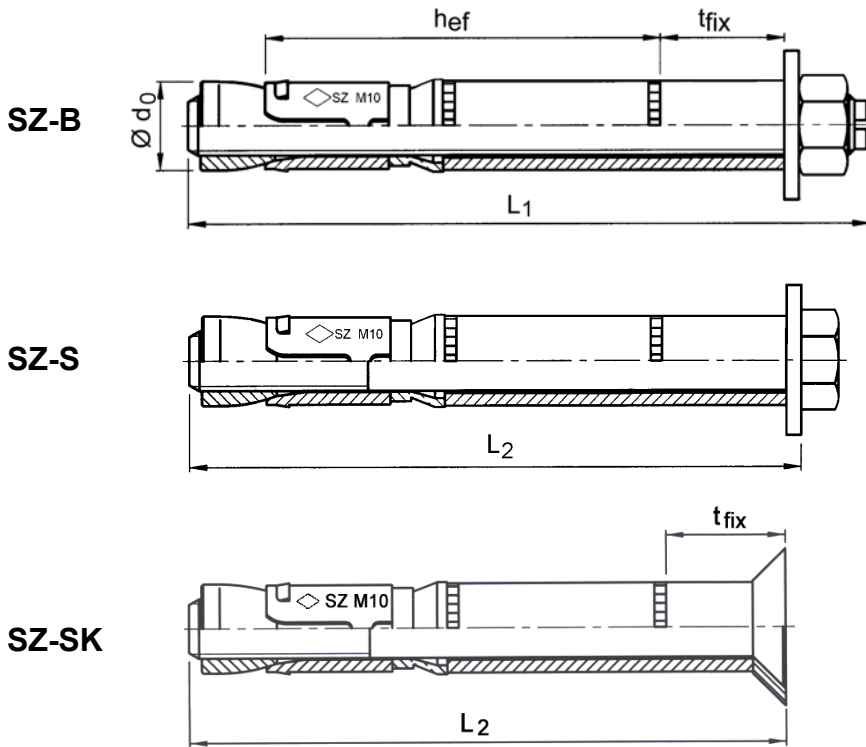

marking:

expansion sleeve:

- Identifying mark of manufacturing plant
- trade name SZ
- size of thread M10

e.g.: SZ M10

Distance sleeve:

- Diameter 15
- max. thickness of fixture 25

e.g.: 15-25

Table 1: Dimensions [mm]

Anchor size			10/M6	12/M8	15/M10	18/M12	24/M16	24/M16L
Size of thread			M6	M8	M10	M12	M16	M16
Threaded bolt	L_1 min	\geq	67	80	96	112	137	152
	L_1 max	\leq	267	280	296	362	437	452
Length of screw	L_2 min	\geq	60	70	85	100	120	135
	L_2 max	\leq	260	270	285	350	420	435
Thickness of fixture	t_{fix} min	\geq	0	0	0	0	0	0
	t_{fix} max	\leq	200	200	200	250	300	300
Thickness of fixture SZ-SK	t_{fix} min	\geq	8	10	14	18	-	-
	t_{fix} max	\leq	200	200	200	250	-	-

MKT Highload Anchor SZ

Dimensions

Annex 2

of European
Technical Approval

ETA-02/0030

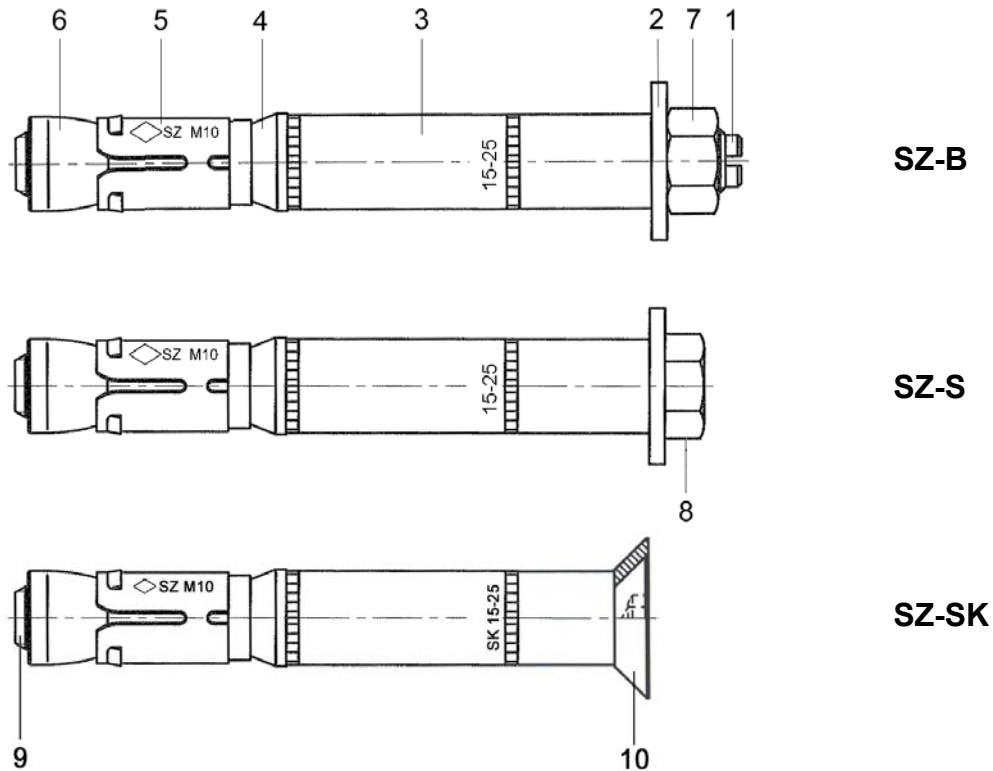

Table 2: Designation of anchor parts and materials

Part	Designation	Materials galvanised $\geq 5 \mu\text{m}$, acc. to EN ISO 4042
1	Threaded bolt	Steel, Strength class 8.8, EN ISO 898-1
2	Washer	Steel, EN 10139
3	Distance sleeve	Precision steel tubes DIN 2394/2393
4	Ring	Polyethylene
5	Expansion sleeve	Steel, EN 10139
6	Threaded cone	Steel, Strength class 8, EN 20898-2
7	Hexagon nut	Steel, Strength class 8, EN 20898-2
8	Hexagon head screw	Steel, Strength class 8.8, EN ISO 898-1
9	Countersunk head screw	Steel, Strength class 8.8, EN ISO 898-1
10	Countersunk washer	Steel, EN 10083-2

MKT Highload Anchor SZ

Materials

Annex 3

of European
Technical Approval

ETA-02/0030

Table 3: Installation parameters

Anchor size			10/M6	12/M8	15/M10	18/M12	24/M16	24/M16L
Effective anchorage depth	h_{ef}	[mm]	50	60	71	80	100	115
Nominal diameter of drill bit	$d_0 =$	[mm]	10	12	15	18	24	24
Cutting diameter of drill bit	$d_{cut} \leq$	[mm]	10.45	12.5	15.5	18.5	24.55	24,55
Depth of drill hole	$h_1 \geq$	[mm]	65	80	95	105	130	145
Recommended setting torque	$T_{inst} =$	[Nm]	15/10 *	30/25 *	50/55 *	80/70 *	160	160
Diameter of clearance hole in the fixture	$d_f \leq$	[mm]	12	14	17	20	26	26
Minimum thickness of member	h_{min}	[mm]	100	120	140	160	200	230
minimum spacing	s_{min}	[mm]	50	60	70	80	100	100
	for $c \geq$	[mm]	80	100	120	160	180	180
minimum edge distance	c_{min}	[mm]	50	60	70	80	100	100
	for $s \geq$	[mm]	100	120	175	200	220	220

* value for anchor type MKT SZ-SK

**MKT Highload Anchor SZ****Installation parameters****Annex 4**of European
Technical Approval**ETA-02/0030**

Table 4: Design method A
Characteristic values to tension loads

Anchor size			10/M6	12/M8	15/M10	18/M12	24/M16	24/M16L
Steel failure								
Characteristic resistance	$N_{Rk,s}$	[kN]	16	29	46	67	126	126
Partial safety factor	γ_{MS}		1.5					
Pull-out failure								
Characteristic resistance in cracked concrete	$N_{Rk,p}$ C20/25	[kN]	5	12	16	1)	1)	1)
Pull-out failure and splitting (choice of minimum spacing and edge distance)								
Characteristic resistance in non-cracked concrete	$N_{Rk,p}$ C20/25	[kN]	12	16	25	30	40	1)
Respective spacing	$s_{cr,sp}$	[mm]	3 h_{ef}					
Respective edge distance	$c_{cr,sp}$	[mm]	1.5 h_{ef}					
Pull-out failure and splitting (choice of maximum resistance)								
Characteristic resistance in non-cracked concrete	$N_{Rk,p}$ C20/25	[kN]	1)	20	30	1)	1)	1)
Respective spacing	$s_{cr,sp}$	[mm]	5 h_{ef}					
Respective edge distance	$c_{cr,sp}$	[mm]	2.5 h_{ef}					
Increasing factors for $N_{Rk,p}$ in cracked and non-cracked concrete	ψ_C	C30/37 C40/50 C50/60	1.22 1.41 1.55					
Partial safety factor	$\gamma_{Mp} = \gamma_{Msp}$		1.5 ²⁾					
Concrete cone failure								
Effective Anchorage depth	h_{ef}	[mm]	50	60	71	80	100	115
Spacing	$s_{cr,N}$	[mm]	3 h_{ef}					
Edge distance	$c_{cr,N}$	[mm]	1.5 h_{ef}					
Partial safety factor	γ_{Mc}		1.5 ²⁾					

1) pull-out is not decisive

2) the partial safety factor $\gamma_2 = 1.0$ is included

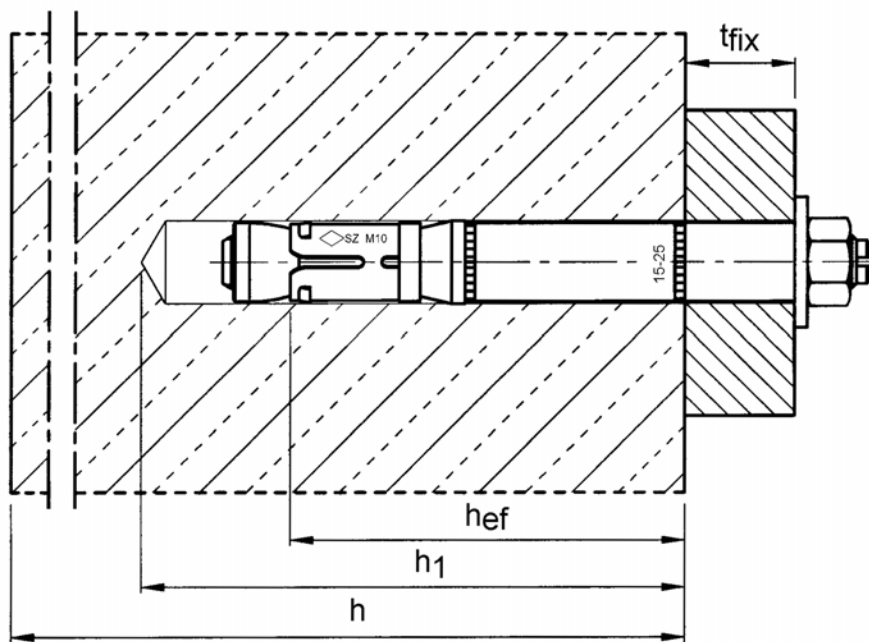
Table 5: Displacements under tension loads

Anchor size			10/M6	12/M8	15/M10	18/M12	24/M16	24/M16L
Tension load in cracked concrete	N	[kN]	2.4	5.7	7.6	12.3	17.1	21.1
Displacement	δ_{N0}	[mm]	0.5	0.5	0.5	0.7	0.8	0.7
	$\delta_{N\infty}$	[mm]	2.0	2.0	1.3	1.3	1.3	1.3
Tension load in non-cracked concrete	$c_{cr,sp} = 1.5 h_{ef}$	[kN]	5.8	7.6	11.9	14.3	19.1	29.6
Displacement	δ_{N0}	[mm]	0.6	0.7	0.8	0.8	0.8	1.3
	$\delta_{N\infty}$	[mm]	2.6	2.6	1.4	1.4	1.4	2.3
Tension load in non-cracked concrete	$c_{cr,sp} = 2.5 h_{ef}$	[kN]	8.5	9.5	14.3	17.2	24	29.6
Displacement	δ_{N0}	[mm]	0.8	1.0	1.1			1.3
	$\delta_{N\infty}$	[mm]	3.4			1.7		

MKT Highload Anchor SZ

Design method A,
Characteristic values for tension loads,
Displacements

Annex 5

of European
Technical Approval

ETA-02/0030

Table 6: Design method A
Characteristic values for shear loads

Anchor size			10/M6	12/M8	15/M10	18/M12	24/M16	24/M16L
Steel failure without lever arm								
SZ-B								
Characteristic resistance	$V_{Rk,s}$	[kN]	16	24.5	36.2	63.2	91.2	91.2
Partial safety factor	$\gamma_{Ms}^{1)}$		1.25					
SZ-S and SZ-SK								
Characteristic resistance	$V_{Rk,s}$	[kN]	17.7	29.9	48.1	72.7	126	126
Partial safety factor	$\gamma_{Ms}^{1)}$		1.25					
Steel failure with lever arm								
Characteristic resistance	$M_{Rk,s}^0$	[Nm]	12	30	60	105	266	266
Partial safety factor	$\gamma_{Ms}^{1)}$		1.25					
Concrete pryout failure								
Factor in equation (5.6) ETAG Annex C, 5.2.3.3	k		1.8	2	2	2	2	2
Partial safety factor	$\gamma_{Mcp}^{1)}$		1.5 ²⁾					
Concrete edge failure								
Effective length of anchor in shear loading	l_f	[mm]	50	60	71	80	100	115
Outside diameter of anchor	d_{nom}	[mm]	10	12	15	18	24	24
Partial safety factor	$\gamma_{Mc}^{1)}$		1.5 ²⁾					

¹⁾ In absence of other national regulations

²⁾ The partial safety factor $\gamma_2 = 1.0$ is included

Table 7: Displacements under shear loads

Anchor size			10/M6	12/M8	15/M10	18/M12	24/M16	24/M16L
Shear load in cracked and non-cracked concrete SZ-B	V	[kN]	9.1	14	20.7	35.1	52.1	52.1
Displacement	δ_{V0}	[mm]	2.5	2.1	2.7	3.0	5.1	5.1
	$\delta_{V\infty}$	[mm]	3.8	3.1	4.1	4.5	7.6	7.6
Shear load in cracked and non-cracked concrete SZ-S and SZ-SK	V	[kN]	10.1	17.1	27.5	41.5	72	72
Displacement	δ_{V0}	[mm]	2.9	2.5	3.6	3.5	7.0	7.0
	$\delta_{V\infty}$	[mm]	4.4	3.8	5.4	5.3	10.5	10.5

MKT Highload Anchor SZ

Design method A,
Characteristic values for shear loads,
Displacements

Annex 6

of European
Technical Approval

ETA-02/0030

Table 8: Characteristic values to tension loads under fire exposure in cracked and non-cracked concrete C20/25 to C50/60

Anchor size	10/M6			12/M8			15/M10			18/M12			24/M16 24/M16L							
	30	60	90	120	30	60	90	120	30	60	90	120	30	60	90	120				
Fire resistance duration R_{\dots} [min]	30	60	90	120	30	60	90	120	30	60	90	120	30	60	90	120				
Steel failure:																				
Characteristic resistance $N_{Rk,s,fi}$ [kN]	1.0	0.8	0.6	0.4	1.9	1.5	1.0	0.8	4.3	3.2	2.1	1.5	6.3	4.6	3.0	2.0	11.6	8.6	5.0	3.1
Pullout failure:																				
Characteristic resistance in concrete C20/25 to C50/60 $N_{Rk,p,fi}$ [kN]	1.3	1.0	1.0	2.4	3.0	3.0	2.4	4.0	3.2	4.0	3.2	3.2	6.3	6.3	5.0	5.0	8.8	8.8	7.0	7.0
Concrete cone failure:																				
Characteristic resistance in concrete C20/25 to C50/60 $N_{Rk,c,fi}^0$ [kN]	3.1	2.5	2.5	4.0	5.0	5.0	4.0	7.6	6.1	7.6	6.1	6.1	10.3	10.3	8.3	8.3	18.0	18.0	14.4	14.4
Spacing	$S_{cr,N,fi}$																			
	4 x h_{ef}																			
Edge Distance	S_{min} [mm]																			
	50																			
Edge Distance	$C_{cr,N,fi}$																			
	2 x h_{ef}																			
C_{min} [mm]																				
$C_{min} = 2 \times h_{ef}$; if fire attack is from more than one side, the edge distance of the anchor has to be bigger than 300 mm.																				

In absence of other national regulations the partial safety factor for resistance under fire exposure $\gamma_{M,fi} = 1.0$ is recommended.

MKT Highload anchor SZ

Characteristic values of tension load resistance under fire exposure

Annex 7

of European
Technical Approval

ETA-02/0030

Table 9: Characteristic values to shear loads under fire exposure in cracked and non-cracked concrete C20/25 to C50/60

Anchor size	10/M6			12/M8			15/M10			18/M12			24/M16 24M16L							
	30	60	90	120	30	60	90	120	30	60	90	120	30	60	90	120				
Fire resistance duration R... [min]	30	60	90	120	30	60	90	120	30	60	90	120	30	60	90	120				
Steel failure without lever arm:																				
Characteristic resistance $V_{Rk,s,fi}$ [kN]	1.0	0.8	0.6	0.4	1.9	1.5	1.0	0.8	4.3	3.2	2.1	1.5	6.3	4.6	3.0	2.0	11.6	8.6	5.0	3.1
Steel failure with lever arm:																				
Characteristic resistance $M^0_{Rk,s,fi}$ [Nm]	0.8	0.6	0.4	0.3	2.0	1.5	1.0	0.8	5.6	4.1	2.7	1.9	9.7	7.2	4.7	3.1	24.8	18.3	11.9	6.6

Concrete pryout failure:

In Equation (5.6) of ETAG 001, Annex C, 5.2.2.3 the k-factor 2.0 (1.8 for M6) and the relevant values of $N^0_{Rk,c,fi}$ of Table 8 have to be considered.

Concrete edge failure:

The initial value $V^0_{Rk,c,fi}$ of the characteristic resistance in concrete C20/25 to C50/60 under fire exposure may be determined by:

$$V^0_{Rk,c,fi} = 0,25 \times V^0_{Rk,c} \quad (R30, R 60, R90) \quad V^0_{Rk,c,fi} = 0,20 \times V^0_{Rk,c} \quad (R120)$$

with $V^0_{Rk,c}$ initial value of the characteristic resistance in cracked concrete C20/25 under normal temperature.

In absence of other national regulations the partial safety factor for resistance under fire exposure $\gamma_{M,fi} = 1.0$ is recommended.

MKT Highload anchor SZ

Characteristic values of shear load resistance under fire exposure

Annex 8

of European
Technical Approval

ETA-02/0030