

Deutsches Institut für Bautechnik

Anstalt des öffentlichen Rechts

Kolonnenstr. 30 L
10829 Berlin
Germany

Tel.: +49(0)30 787 30 0
Fax: +49(0)30 787 30 320
E-mail: dibt@dibt.de
Internet: www.dibt.de

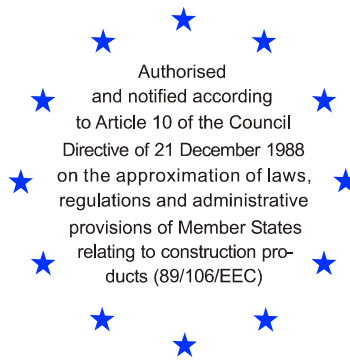

DIBt

Mitglied der EOTA
Member of EOTA

European Technical Approval ETA-05/0252

English translation prepared by DIBt - Original version in German language

Handelsbezeichnung <i>Trade name</i>	MKT Injektionssystem VMU A4 für Beton <i>MKT Injection System VMU A4 for concrete</i>
Zulassungsinhaber <i>Holder of approval</i>	MKT Metall-Kunststoff-Technik GmbH & Co. KG Auf dem Immel 2 67685 Weilerbach
Zulassungsgegenstand und Verwendungszweck	Verbunddübel mit Ankerstange aus nichtrostendem Stahl in den Größen M10, M12 und M16 zur Verankerung im ungerissenen Beton
<i>Generic type and use of construction product</i>	<i>Bonded anchor with anchor rod of sizes M10, M12 and M16 made of stainless steel for use in non-cracked concrete</i>
Geltungsdauer: <i>Validity:</i>	vom <i>from</i> 19 January 2006 bis <i>to</i> 19 January 2011
Herstellwerk <i>Manufacturing plant</i>	MKT Metall-Kunststoff-Technik GmbH & Co. KG Auf dem Immel 2 67685 Weilerbach

Diese Zulassung umfasst
This Approval contains

15 Seiten einschließlich 7 Anhänge
15 pages including 7 annexes



Europäische Organisation für Technische Zulassungen
European Organisation for Technical Approvals

I LEGAL BASES AND GENERAL CONDITIONS

- 1 This European Technical Approval is issued by Deutsches Institut für Bautechnik in accordance with:
 - Council Directive 89/106/EEC of 21 December 1988 on the approximation of laws, regulations and administrative provisions of Member States relating to construction products¹, modified by Council Directive 93/68/EEC² and Regulation (EC) N° 1882/2003 of the European Parliament and of the Council³;
 - Gesetz über das In-Verkehr-Bringen von und den freien Warenverkehr mit Bauprodukten zur Umsetzung der Richtlinie 89/106/EWG des Rates vom 21. Dezember 1988 zur Angleichung der Rechts- und Verwaltungsvorschriften der Mitgliedstaaten über Bauprodukte und anderer Rechtsakte der Europäischen Gemeinschaften (Bauproduktengesetz - BauPG) vom 28. April 1998⁴, zuletzt geändert durch Gesetz vom ('last amended by law on') 06.01.2004⁵;
 - Common Procedural Rules for Requesting, Preparing and the Granting of European Technical Approvals set out in the Annex to Commission Decision 94/23/EC⁶;
 - Guideline for European Technical Approval of "Metal anchors for use in concrete - Part 5: Bonded anchors", ETAG 001-05.
- 2 Deutsches Institut für Bautechnik is authorized to check whether the provisions of this European Technical Approval are met. Checking may take place in the manufacturing plant. Nevertheless, the responsibility for the conformity of the products to the European Technical Approval and for their fitness for the intended use remains with the holder of the European Technical Approval.
- 3 This European Technical Approval is not to be transferred to manufacturers or agents of manufacturers other than those indicated on page 1, or manufacturing plants other than those indicated on page 1 of this European Technical Approval.
- 4 This European Technical Approval may be withdrawn by Deutsches Institut für Bautechnik, in particular pursuant to information by the Commission according to Article 5(1) of Council Directive 89/106/EEC.
- 5 Reproduction of this European Technical Approval including transmission by electronic means shall be in full. However, partial reproduction can be made with the written consent of Deutsches Institut für Bautechnik. In this case partial reproduction has to be designated as such. Texts and drawings of advertising brochures shall not contradict or misuse the European Technical Approval.
- 6 The European Technical Approval is issued by the approval body in its official language. This version corresponds fully to the version circulated in EOTA. Translations into other languages have to be designated as such.

1 Official Journal of the European Communities N° L 40, 11.2.1989, p. 12

2 Official Journal of the European Communities N° L 220, 30.8.1993, p. 1

3 Official Journal of the European Union N° L 284, 31.10.2003, p. 25

4 Bundesgesetzblatt I, p. 812

5 Bundesgesetzblatt I, p.2, 15

6 Official Journal of the European Communities N° L 17, 20.1.1994, p. 34

II SPECIFIC CONDITIONS OF THE EUROPEAN TECHNICAL APPROVAL

1 Definition of the construction product and intended use

1.1 Definition of the product

The MKT Injection System VMU A4 for concrete is a bonded anchor consisting of a mortar cartridge with MKT Injection Adhesive VMU and an anchor rod with hexagon nut and washer of sizes M10, M12 and M16. The anchor rod (including nut and washer) is made of stainless steel.

The anchor rod is anchored via the bond between anchor rod, chemical mortar and concrete.

An illustration of the product and intended use is given in Annex 1.

1.2 Intended use

The anchor is intended to be used for anchorages for which requirements for mechanical resistance and stability and safety in use in the sense of the Essential Requirements 1 and 4 of Council Directive 89/106 EEC shall be fulfilled and failure of anchorages made with these products would cause risk to human life and/or lead to considerable economic consequences. Safety in case of fire (Essential Requirement 2) is not covered in this European Technical Approval. The anchor is to be used only for anchorages subject to static or quasi-static loading in reinforced or unreinforced normal weight concrete of strength classes C20/25 at minimum and C50/60 at most according to EN 206:2000-12.

The anchor may be anchored in non-cracked concrete only.

The anchor may be used in structures subject to dry internal conditions and also in structures subject to external atmospheric exposure (including industrial and marine environment), or exposure in permanently damp internal conditions, if no particular aggressive conditions exist. Such particular aggressive conditions are e.g. permanent, alternating immersion in seawater or the splash zone of seawater, chloride atmosphere of indoor swimming pools or atmosphere with extreme chemical pollution (e.g. in desulphurization plants or road tunnels where de-icing materials are used).

It may be installed in dry or wet concrete.

The anchor may be used in the following temperature ranges:

Temperature range I: -40 °C to +80 °C (max long term temperature +50 °C and
max short term temperature +80 °C)

Temperature range II: -40 °C to +120 °C (max long term temperature +72 °C and
max short term temperature +120 °C)

The provisions made in this European Technical Approval are based on an assumed working life of the anchor of 50 years. The indications given on the working life cannot be interpreted as a guarantee given by the producer, but are to be regarded only as a means for choosing the right products in relation to the expected economically reasonable working life of the works.

2 Characteristics of product and methods of verification

2.1 Characteristics of product

The anchor corresponds to the drawings and provisions given in Annexes 1 to 4. The characteristic material values, dimensions and tolerances of the anchor not indicated in

Annexes 1 to 4 shall correspond to the respective values laid down in the technical documentation⁷ of this European Technical Approval.

The characteristic values for the design of anchorages are given in Annexes 5 to 7.

Each mortar cartridge shall be marked with the imprint MKT Injection Adhesive VMU, processing notes, charge code, shelf-life, hazard code and curing- and processing time in accordance with Annex 2. Each anchor rod shall be marked with the identifying mark of the producer, with a marking of the thread size, an additional marking of length for anchor size M12 and the letters "A4" for the stainless steel in accordance with Annex 2.

2.2 Methods of verification

The assessment of fitness of the anchor for the intended use in relation to the requirements for mechanical resistance and stability and safety in use in the sense of the Essential Requirements 1 and 4 has been made in accordance with the "Guideline for European Technical Approval of Metal Anchors for Use in Concrete", Part 1 "Anchors in general" and Part 5 "Bonded anchors", on the basis of Option 7.

In addition to the specific clauses relating to dangerous substances contained in this European Technical Approval, there may be other requirements applicable to the products falling within its scope (e.g. transposed European legislation and national laws, regulations and administrative provisions). In order to meet the provisions of the Construction Products Directive, these requirements need also to be complied with, when and where they apply.

3 Evaluation and attestation of conformity and CE marking

3.1 System of attestation of conformity

According to the decision 96/582/EG of the European Commission⁸ the system 2(i) (referred to as System 1) of attestation of conformity applies.

This system of attestation of conformity is defined as follows:

System 1: Certification of the conformity of the product by an approved certification body on the basis of:

(a) Tasks for the manufacturer:

- (1) factory production control;
- (2) further testing of samples taken at the factory by the manufacturer in accordance with a prescribed test plan;

(b) Tasks for the approved body:

- (3) initial type-testing of the product;
- (4) initial inspection of factory and of factory production control;
- (5) continuous surveillance, assessment and approval of factory production control.

Note: Approved bodies are also referred to as "notified bodies".

3.2 Responsibilities

3.2.1 Tasks of the manufacturer

3.2.1.1 Factory production control

The manufacturer shall exercise permanent internal control of production. All the elements, requirements and provisions adopted by the manufacturer shall be documented in a systematic manner in the form of written policies and procedures, including records of results performed. This production control system shall insure that the product is in conformity with this European Technical Approval.

⁷ The technical documentation of this European Technical Approval is deposited at the Deutsches Institut für Bautechnik and, as far as relevant for the tasks of the approved bodies involved in the attestation of conformity procedure, is handed over to the approved bodies.

⁸ Official Journal of the European Communities L 254 of 08.10.1996

The manufacturer may only use initial / raw / constituent materials stated in the technical documentation of this European Technical Approval.

The factory production control shall be in accordance with the control plan of January 2006 which is part of the technical documentation of this European Technical Approval. The control plan is laid down in the context of the factory production control system operated by the manufacturer and deposited at Deutsches Institut für Bautechnik.⁹

The results of factory production control shall be recorded and evaluated in accordance with the provisions of the control plan.

3.2.1.2 Other tasks of manufacturer

The manufacturer shall, on the basis of a contract, involve a body which is approved for the tasks referred to in section 3.1 in the field of anchors in order to undertake the actions laid down in section 3.2.2. For this purpose, the control plan referred to in sections 3.2.1.1 and 3.2.2 shall be handed over by the manufacturer to the approved body involved.

The manufacturer shall make a declaration of conformity, stating that the construction product is in conformity with the provisions of this European Technical Approval.

3.2.2 Tasks of approved bodies

The approved body shall perform the following tasks in accordance with the provisions laid down in the control plan:

- initial type-testing of the product,
- initial inspection of factory and of factory production control,
- continuous surveillance, assessment and approval of factory production control.

The approved body shall retain the essential points of its actions referred to above and state the results obtained and conclusions drawn in a written report.

The approved certification body involved by the manufacturer shall issue an EC certificate of conformity of the product stating the conformity with the provisions of this European Technical Approval.

In cases where the provisions of the European Technical Approval and its control plan are no longer fulfilled the certification body shall withdraw the certificate of conformity and inform Deutsches Institut für Bautechnik without delay.

3.3 CE marking

The CE marking shall be affixed on each packaging of anchors. The letters "CE" shall be followed by the identification number of the approved certification body, where relevant, and be accompanied by the following additional information:

- the name and address of the producer (legal entity responsible for the manufacturer),
- the last two digits of the year in which the CE marking was affixed,
- the number of the EC certificate of conformity for the product,
- the number of the European Technical Approval,
- the number of the guideline for European Technical Approval,
- use category (ETAG 001-1, Option 7),
- size.

4 Assumptions under which the fitness of the product for the intended use was favourably assessed

4.1 Manufacturing

The anchor is manufactured in accordance with the provisions of the European Technical Approval using the automated manufacturing process as identified in the inspection of the

⁹ The control plan is a confidential part of the European Technical Approval and only handed over to the approved body involved in the procedure of attestation of conformity. See section 3.2.2.

plant by the Deutsches Institut für Bautechnik and the approved body and laid down in the technical documentation.

The European Technical Approval is issued for the product on the basis of agreed data/information, deposited with Deutsches Institut für Bautechnik, which identifies the product that has been assessed and judged. Changes to the product or production process, which could result in this deposited data/information being incorrect, should be notified to Deutsches Institut für Bautechnik before the changes are introduced. Deutsches Institut für Bautechnik will decide whether or not such changes affect the European Technical Approval and consequently the validity of the CE marking on the basis of the European Technical Approval and if so whether further assessment or alterations to the European Technical Approval shall be necessary.

4.2 Installation

4.2.1 Design of anchorages

The fitness of the anchor for the intended use is given under the following conditions:

The anchorages are designed in accordance with the "Guideline for European Technical Approval of Metal Anchors for Use in Concrete", Annex C, Method A, for bonded anchors under the responsibility of an engineer experienced in anchorages and concrete work.

For the verifications given below according to Annex C the following shall be observed:

- For the verification 'concrete cone failure' (clause 5.2.2.4, Annex C of the Guideline) $N_{Rk,c}$ shall be determined according to (1) and (2): The smaller of the values according to (1) and (2) is decisive.

(1) $N_{Rk,c}$ according to equation (5.2), Annex C of the Guideline

$$\begin{aligned} \text{where: } N_{Rk,c}^0 & \text{ according to Annex 6,} \\ S_{cr,N} & \text{ according to Annex 6,} \\ C_{cr,N} & \text{ according to Annex 6,} \\ \Psi_{ucr,N} & = 1,0 \end{aligned}$$

In special cases according to clause 5.2.2.4 g, Annex C of the Guideline the method given there is valid. However, the value $N_{Rk,c}^0$ shall be calculated according to the following equation:

$$N_{Rk,c}^0 = N_{Rk,c}^0 (\text{Annex 6}) \times \frac{h'_{ef}}{h_{ef}}$$

(2) $N_{Rk,c}$ according to equation (5.2), Annex C of the Guideline

$$\begin{aligned} \text{where: } N_{Rk,c}^0 & = 0,75 \times 15,5 \times h_{ef}^{1,5} \times f_{ck,cube}^{0,5} \\ S_{cr,N} & = 3 h_{ef} \\ C_{cr,N} & = 1,5 h_{ef} \\ \Psi_{ucr,N} & = 1,0 \end{aligned}$$

For the verification 'splitting failure due to loading' (clause 5.2.2.6, Annex C of the Guideline) $N_{Rk,sp}$ shall be determined according to (3).

(3) $N_{Rk,sp}$ according to equation (5.3), Annex C of the Guideline

$$\begin{aligned} \text{where: } N_{Rk,c}^0 & \text{ according to Annex 6,} \\ S_{cr,sp} & \text{ according to Annex 6,} \\ C_{cr,sp} & \text{ according to Annex 6,} \\ \Psi_{ucr,N} & = 1,0 \\ \Psi_{h,sp} & = 1,0 \end{aligned}$$

- For the verification 'concrete pryout failure' (clause 5.2.3.3, Annex C of the Guideline) $N_{Rk,c}$ for equation (5.6), Annex C of the Guideline, shall be determined according to (1).

Verifiable calculation notes and drawings are prepared taking account of the loads to be anchored.

The position of the anchor is indicated on the design drawings (e.g. position of the anchor relative to reinforcement or to supports, etc.).

4.2.2 Installation of anchors

The fitness for use of the anchor can only be assumed if the anchor is installed as follows:

- anchor installation carried out by appropriately qualified personnel and under the supervision of the person responsible for technical matters of the site,
- use of the anchor only as supplied by the manufacturer without exchanging the components of an anchor,
- anchor installation in accordance with the manufacturer's specifications and drawings using the tools indicated in the technical documentation of this European Technical Approval,
- checks before placing the anchor to ensure that the strength class of the concrete in which the anchor is to be placed is in the range given and is not lower than that of the concrete to which the characteristic loads apply,
- check of concrete being well compacted, e.g. without significant voids,
- keeping the effective anchorage depth,
- Edge distance and spacing not less than the specified values without minus tolerances,
- positioning of the drill holes without damaging the reinforcement,
- in case of aborted drill hole: the drill hole shall be filled with mortar,
- cleaning the drill hole by at least 2x blowing / 2x brushing / 2x blowing.
- the anchor component installation temperature shall be at least +5 °C;
- the temperature of the concrete during installation and curing of the chemical mortar must not fall below -5 °C;
- the curing time according to Annex 3 shall be observed before the anchor may be loaded,
- after the curing time fixing the member to be anchored by using a calibrated torque wrench by not exceeding the torque moment given in Annex 5.

5 Indications to the manufacturer

5.1 Responsibility of the manufacturer

It is in the responsibility of the manufacturer to ensure that the information on the specific conditions according to 1 and 2 including Annexes referred to and 4.2.1 and 4.2.2 as well as 5.1 is given to those who are concerned. This information may be made by reproduction of the respective parts of the European Technical Approval. In addition all installation data shall be shown clearly on the package and/or on an enclosed instruction sheet, preferably using illustration(s).

The minimum data required are:

- drill bit diameter,
- hole depth,
- diameter of anchor rod,
- minimum effective anchorage depth,
- maximum thickness of the fixture,
- information on the installation procedure, including cleaning of the hole with the cleaning equipments, preferably by means of an illustration,

- anchor component installation temperature,
- ambient temperature of the concrete during installation of the anchor,
- admissible processing time (open time) of the mortar,
- curing time until the anchor may be loaded as a function of the ambient temperature in the concrete during installation,
- torque moment,
- identification of the manufacturing batch.

All data shall be presented in a clear and explicit form.

5.2 Packaging, transport and storage

The injection cartridges shall be protected against sun radiation and shall be stored according to the manufacturer's installation instructions in dry condition at temperatures of at least +5 °C to not more than +25 °C.

Mortar cartridges with expired shelf life must no longer be used.

The anchor shall only be packaged and supplied as a complete unit. Mortar cartridges may be packed separately from anchor rods, nuts and washers.

The manufacturer's installation instruction shall indicate that the MKT Injection Adhesive VMU shall be used with the corresponding anchor rods of the manufacturer according to Annex 2.

Dipl.-Ing. E. Jasch

beglaubigt:
Lange

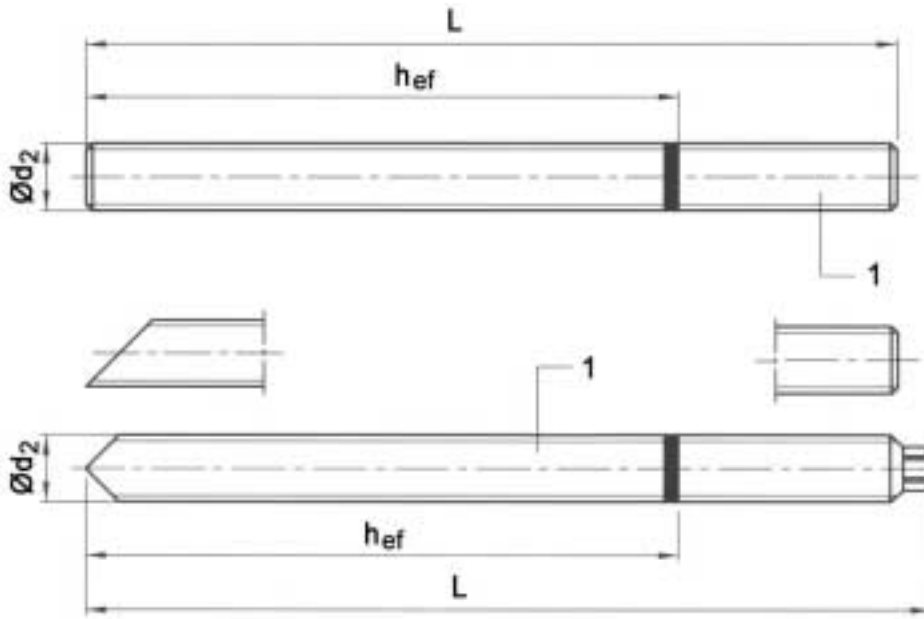

Marking: e.g.

⊠ M12 A4

◇ Identifying mark of manufacturing plant

additional marking of lengths for anchor size M12

H marking of length

M12 Size of thread

A4 Stainless steel A4

Marking of length	F	G	H	I	J	K	L	M
Length of anchor min ≥	101,6	114,3	127,0	139,7	152,4	165,1	177,8	190,5
Length of anchor max <	114,3	127,0	139,7	152,4	165,1	177,8	190,5	203,2



Marking of length	N	O	P	Q	R	S	T	U	V	W	X	Y	Z
Length of anchor min ≥	203,2	215,9	228,6	241,3	254,0	279,4	304,8	330,2	355,6	381,0	406,4	431,8	457,2
Length of anchor max <	215,9	228,6	241,3	254,0	279,4	304,8	330,2	355,6	381,0	406,4	431,8	457,2	483,0

Dimensions in mm

Table 1: Anchor dimensions

Size	Anchor rod		
	Ø d ₂ [mm]	h _{ef} [mm]	min L ¹⁾ [mm]
M10	10	90	≥ 101
M12	12	110	≥ 124
M16	16	125	≥ 143

¹⁾ max L = 1500 mm

MKT Injection System VMU A4 for concrete

Anchor dimensions

Annex 2

of European
Technical Approval

ETA-05/0252

Table 2: Materials

	Designation	
1	Anchor rod	Stainless Steel, 1.4401, 1.4404, 1.4571, EN 10088
2	Hexagon nut according to DIN 934	ISO 3506, A4-70, 1.4401, 1.4571, EN 10088
3	Washer	Stainless steel, 1.4401, 1.4571, EN 10088
4	Mortar cartridge	Vinylester resin, styrene free

Table 3: Minimum curing time

Temperature [°C] in the drill hole	Maximum processing time [minutes]	Minimum curing time [minutes]	
		dry concrete	wet concrete
+ 40 °C	1.4	15	30
+ 35 °C	2	20	40
+ 30 °C	4	25	50
+ 20 °C	6	45	90
+ 10 °C	12	80	160
+ 5 °C	20	120	240
0 °C	45	180	360
- 5 °C	90	330	660

MKT Injection System VMU A4 for concrete

**Materials,
Curing times depending on the temperature**

Annex 3

of European
Technical Approval

ETA-05/0252

Mortar cartridges VMU
(different container sizes)

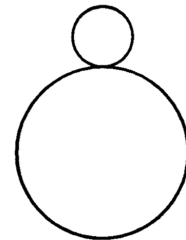
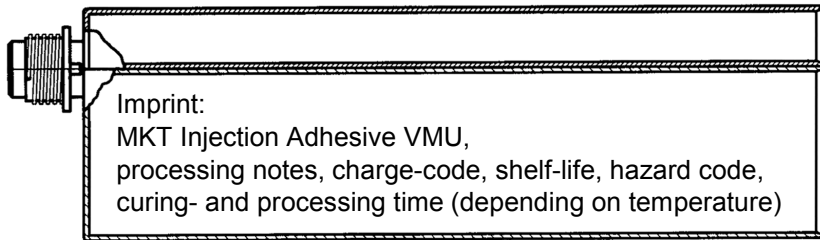
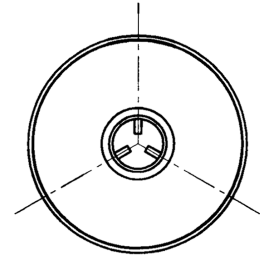
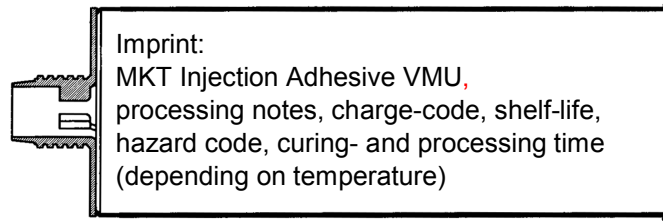

Sealing cap



Static mixer

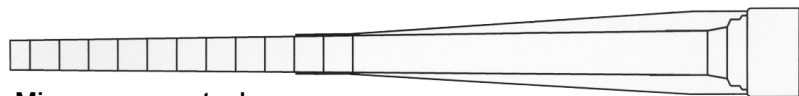

Mixer, one-way tool,
must be changed in case of working interruption

MKT Injection System VMU A4 for concrete

Mortar cartridges

Annex 4

of European
Technical Approval

ETA-05/0252

Table 4: Installation parameters

Anchor size		M10	M12	M16
Nominal diameter of drill hole	$d_0 =$ [mm]	12	14	18
Cutting diameter of drill hole	$d_{cut} \leq$ [mm]	12.5	14.5	18.5
Depth of drill hole	$h_0 \geq$ [mm]	90	110	125
Diameter of clearance hole in the fixture	$d_f \leq$ [mm]	12	14	18
Diameter of steel brush	$D \geq$ [mm]	13	15	19
Torque moment	$T_{inst} =$ [Nm]	20	40	60
Thickness of fixture	$\min t_{fix} >$ [mm]	0		
	$\max t_{fix} <$ [mm]	1399	1376	1357
Effective anchorage depth	$h_{ef} =$ [mm]	90	110	125
Minimum thickness of concrete	$h_{min} =$ [mm]	130	160	200
Reduced Minimum thickness of concrete	$h_{min,red} =$ [mm]	120	140	160
Minimum spacing	$s_{min} =$ [mm]	45	55	65
Minimum edge distance	$c_{min} =$ [mm]	45	55	65

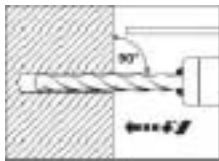
Steel brush**Installation**

Drilling

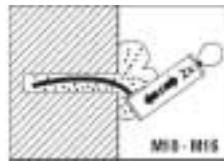

2x blowing,

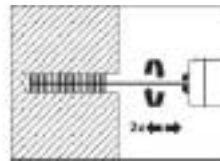

2x brushing,

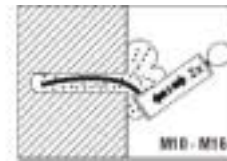

2x blowing

**MKT Injection System VMU A4 for concrete****Installation parameters****Annex 5**of European
Technical Approval**ETA-05/0252**

Table 5: Design method A
Characteristic values for tension loads

Anchor size			M10	M12	M16
Steel failure					
Characteristic tension resistance	$N_{Rk,s}$	[kN]	40.6	59	110
Partial safety factor	$\gamma_{Ms}^{1)}$	-	1.5		
Pullout and concrete cone failure					
Effective anchorage depth	h_{ef}	[mm]	90	110	125
Non-cracked concrete C20/25 (50°C / 80°C) ⁴⁾	$N_{Rk,c}^0 = N_{Rk,p}$	[kN]	25	35	50
Non-cracked concrete C20/25 (72°C / 120°C) ⁴⁾	$N_{Rk,c}^0 = N_{Rk,p}$	[kN]	16	25	40
Increasing factors for non-cracked concrete ψ_c	C30/37	-	1.12		
	C40/50	-	1.23		
	C50/60	-	1.30		
Characteristic edge distance	$c_{cr,N}$	[mm]	90	110	125
Characteristic spacing	$s_{cr,N}$	[mm]	180	220	250
Partial safety factor	$\gamma_{Mc} = \gamma_{Mp}^{1) 2)}$	-	1.5 / 1.8 ³⁾	1.5	1.5
Splitting failure					
Standard minimum thickness of concrete slab	h_{min}	[mm]	130	160	200
Edge distance	$c_{cr,sp}$	[mm]	90	110	125
Spacing	$s_{cr,sp}$	[mm]	180	220	250
reduced minimum thickness of concrete slab	$h_{min,red}$	[mm]	120	140	160
Edge distance	$c_{cr,sp}$	[mm]	145	180	200
Spacing	$s_{cr,sp}$	[mm]	290	360	400
Partial safety factor	$\gamma_{Msp}^{1) 2)}$	-	1.5 / 1.8 ³⁾	1.5	1.5

¹⁾ In absence of other national regulations

²⁾ The partial safety factor $\gamma_2 = 1.0$ is included

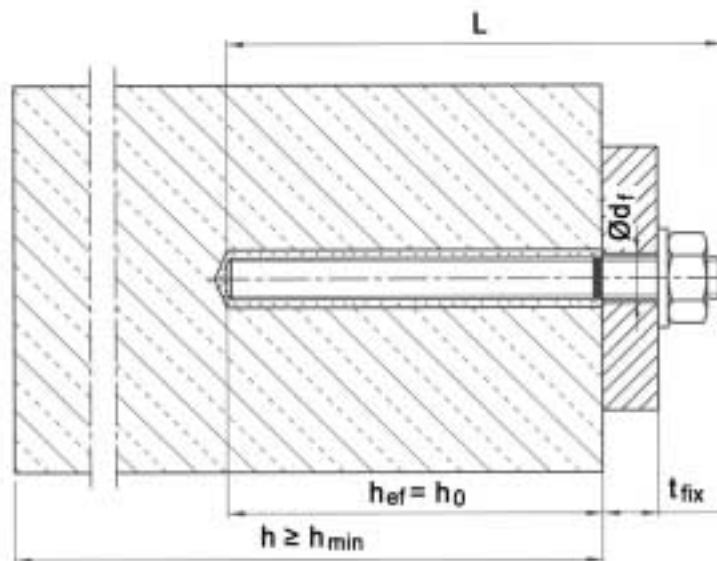
³⁾ M10: $\gamma_{Mc} = \gamma_{Mp} = 1.5$ in dry and wet concrete, $\gamma_{Mc} = \gamma_{Mp} = 1.8$ in flooded hole.

⁴⁾ Maximum long term temperature / maximum short term temperature

Table 6: Displacements under tension loads

Anchor size			M 10	M12	M16
Tension load	N	[kN]	11.9	16.7	23.8
Displacement	δ_{N0}	[mm]	0.1	0.1	0.1
	$\delta_{N\infty}$	[mm]	0.2		

MKT Injection System VMU A4 for concrete

Design Method A
Characteristic values for tension loads;
Displacements

Annex 6

of European
Technical Approval

ETA-05/0252

Table 7: Design method A
Characteristic values for shear loads

Anchor size			M10	M12	M16
Steel failure without lever arm					
Characteristic shear resistance	$V_{Rk,s}$	[kN]	20.3	29.5	55.0
Partial safety factor	$\gamma_{Ms}^{1)}$	-	1.25		
Steel failure with lever arm					
Characteristic bending moments	$M_{Rk,s}^0$	[Nm]	52	92	233
Partial safety factor	$\gamma_{Ms}^{1)}$	-	1.25		
Concrete pryout failure					
Factor in equation (5.6) ETAG Annex C, 5.2.3.3	k	-	2		
Partial safety factor	$\gamma_{Mc}^{1)}$	-	1.5 ²⁾		
Concrete edge failure					
Effective length of anchor in shear loading	l_f	[mm]	90	110	125
Diameter of anchor	d_{nom}	[mm]	12	14	18
Partial safety factor	$\gamma_{Mc}^{1)}$	-	1.5 ²⁾		

¹⁾ In absence of other national regulations

²⁾ The partial safety factor $\gamma_2 = 1.0$ is included

Table 8: Displacements under shear loads

Anchor size			M10	M12	M16
Shear load	V	[kN]	11.6	16.9	31.4
Displacement	δ_{V0}	[mm]	0.6	1.1	1.7
	$\delta_{V\infty}$	[mm]	0.9	1.7	2.6

MKT Injection System VMU A4 for concrete

Design Method A
Characteristic values for shear loads;
Displacements

Annex 7

of European
 Technical Approval

ETA-05/0252