

# Deutsches Institut für Bautechnik

Anstalt des öffentlichen Rechts

Kolonnenstr. 30 L  
10829 Berlin  
Germany

Tel.: +49(0)30 787 30 0  
Fax: +49(0)30 787 30 320  
E-mail: [dibt@dibt.de](mailto:dibt@dibt.de)  
Internet: [www.dibt.de](http://www.dibt.de)

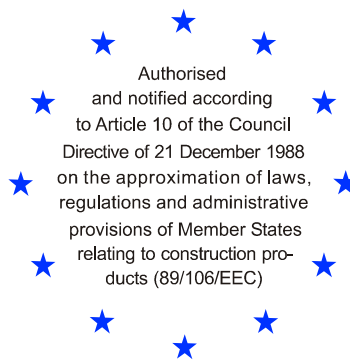

# DIBt

Mitglied der EOTA  
Member of EOTA

## European Technical Approval ETA-05/0253

English translation prepared by DIBt - Original version in German language

Handelsbezeichnung <i>Trade name</i>	MKT Injektionssystem VMU für Beton <i>MKT Injection System VMU for concrete</i>
Zulassungsinhaber <i>Holder of approval</i>	MKT Metall-Kunststoff-Technik GmbH & Co. KG Auf dem Immel 2 67685 Weilerbach
Zulassungsgegenstand und Verwendungszweck	Verbunddübel mit Ankerstange aus verzinktem Stahl in den Größen M10, M12 und M16 zur Verankerung im ungerissenen Beton
<i>Generic type and use of construction product</i>	<i>Bonded anchor with anchor rod of sizes M10, M12 and M16 made of galvanised steel for use in non-cracked concrete</i>
Geltungsdauer: <i>Validity:</i>	vom <i>from</i> 19 January 2006 bis <i>to</i> 19 January 2011
Herstellwerk <i>Manufacturing plant</i>	MKT Metall-Kunststoff-Technik GmbH & Co. KG Auf dem Immel 2 67685 Weilerbach

Diese Zulassung umfasst  
*This Approval contains*

15 Seiten einschließlich 7 Anhänge  
*15 pages including 7 annexes*



Europäische Organisation für Technische Zulassungen  
European Organisation for Technical Approvals

## I LEGAL BASES AND GENERAL CONDITIONS

- 1 This European Technical Approval is issued by Deutsches Institut für Bautechnik in accordance with:
  - Council Directive 89/106/EEC of 21 December 1988 on the approximation of laws, regulations and administrative provisions of Member States relating to construction products<sup>1</sup>, modified by Council Directive 93/68/EEC<sup>2</sup> and Regulation (EC) N° 1882/2003 of the European Parliament and of the Council<sup>3</sup>;
  - Gesetz über das In-Verkehr-Bringen von und den freien Warenverkehr mit Bauprodukten zur Umsetzung der Richtlinie 89/106/EWG des Rates vom 21. Dezember 1988 zur Angleichung der Rechts- und Verwaltungsvorschriften der Mitgliedstaaten über Bauprodukte und anderer Rechtsakte der Europäischen Gemeinschaften (Bauproduktengesetz - BauPG) vom 28. April 1998<sup>4</sup>, zuletzt geändert durch Gesetz vom ('last amended by law on') 06.01.2004<sup>5</sup>;
  - Common Procedural Rules for Requesting, Preparing and the Granting of European Technical Approvals set out in the Annex to Commission Decision 94/23/EC<sup>6</sup>;
  - Guideline for European Technical Approval of "Metal anchors for use in concrete - Part 5: Bonded anchors", ETAG 001-05.
- 2 Deutsches Institut für Bautechnik is authorized to check whether the provisions of this European Technical Approval are met. Checking may take place in the manufacturing plant. Nevertheless, the responsibility for the conformity of the products to the European Technical Approval and for their fitness for the intended use remains with the holder of the European Technical Approval.
- 3 This European Technical Approval is not to be transferred to manufacturers or agents of manufacturers other than those indicated on page 1, or manufacturing plants other than those indicated on page 1 of this European Technical Approval.
- 4 This European Technical Approval may be withdrawn by Deutsches Institut für Bautechnik, in particular pursuant to information by the Commission according to Article 5(1) of Council Directive 89/106/EEC.
- 5 Reproduction of this European Technical Approval including transmission by electronic means shall be in full. However, partial reproduction can be made with the written consent of Deutsches Institut für Bautechnik. In this case partial reproduction has to be designated as such. Texts and drawings of advertising brochures shall not contradict or misuse the European Technical Approval.
- 6 The European Technical Approval is issued by the approval body in its official language. This version corresponds fully to the version circulated in EOTA. Translations into other languages have to be designated as such.

---

1 Official Journal of the European Communities N° L 40, 11.2.1989, p. 12

2 Official Journal of the European Communities N° L 220, 30.8.1993, p. 1

3 Official Journal of the European Union N° L 284, 31.10.2003, p. 25

4 Bundesgesetzblatt I, p. 812

5 Bundesgesetzblatt I, p.2, 15

6 Official Journal of the European Communities N° L 17, 20.1.1994, p. 34



producer, with a marking of the thread size and an additional marking of length for anchor size M12 in accordance with Annex 2.

## 2.2 Methods of verification

The assessment of fitness of the anchor for the intended use in relation to the requirements for mechanical resistance and stability and safety in use in the sense of the Essential Requirements 1 and 4 has been made in accordance with the "Guideline for European Technical Approval of Metal Anchors for Use in Concrete", Part 1 "Anchors in general" and Part 5 "Bonded anchors", on the basis of Option 7.

In addition to the specific clauses relating to dangerous substances contained in this European Technical Approval, there may be other requirements applicable to the products falling within its scope (e.g. transposed European legislation and national laws, regulations and administrative provisions). In order to meet the provisions of the Construction Products Directive, these requirements need also to be complied with, when and where they apply.

## 3 Evaluation and attestation of conformity and CE marking

### 3.1 System of attestation of conformity

According to the decision 96/582/EG of the European Commission<sup>8</sup> the system 2(i) (referred to as System 1) of attestation of conformity applies.

This system of attestation of conformity is defined as follows:

System 1: Certification of the conformity of the product by an approved certification body on the basis of:

(a) Tasks for the manufacturer:

- (1) factory production control;
- (2) further testing of samples taken at the factory by the manufacturer in accordance with a prescribed test plan;

(b) Tasks for the approved body:

- (3) initial type-testing of the product;
- (4) initial inspection of factory and of factory production control;
- (5) continuous surveillance, assessment and approval of factory production control.

Note: Approved bodies are also referred to as "notified bodies".

### 3.2 Responsibilities

#### 3.2.1 Tasks of the manufacturer

##### 3.2.1.1 Factory production control

The manufacturer shall exercise permanent internal control of production. All the elements, requirements and provisions adopted by the manufacturer shall be documented in a systematic manner in the form of written policies and procedures, including records of results performed. This production control system shall insure that the product is in conformity with this European Technical Approval.

The manufacturer may only use initial / raw / constituent materials stated in the technical documentation of this European Technical Approval.

The factory production control shall be in accordance with the control plan of January 2006 which is part of the technical documentation of this European Technical Approval. The control plan is laid down in the context of the factory production control system operated by the manufacturer and deposited at Deutsches Institut für Bautechnik.<sup>9</sup>

---

<sup>8</sup> Official Journal of the European Communities L 254 of 08.10.1996

<sup>9</sup> The control plan is a confidential part of the European Technical Approval and only handed over to the approved body involved in the procedure of attestation of conformity. See section 3.2.2.

The results of factory production control shall be recorded and evaluated in accordance with the provisions of the control plan.

#### 3.2.1.2 Other tasks of manufacturer

The manufacturer shall, on the basis of a contract, involve a body which is approved for the tasks referred to in section 3.1 in the field of anchors in order to undertake the actions laid down in section 3.2.2. For this purpose, the control plan referred to in sections 3.2.1.1 and 3.2.2 shall be handed over by the manufacturer to the approved body involved.

The manufacturer shall make a declaration of conformity, stating that the construction product is in conformity with the provisions of this European Technical Approval.

#### 3.2.2 Tasks of approved bodies

The approved body shall perform the following tasks in accordance with the provisions laid down in the control plan:

- initial type-testing of the product,
- initial inspection of factory and of factory production control,
- continuous surveillance, assessment and approval of factory production control.

The approved body shall retain the essential points of its actions referred to above and state the results obtained and conclusions drawn in a written report.

The approved certification body involved by the manufacturer shall issue an EC certificate of conformity of the product stating the conformity with the provisions of this European Technical Approval.

In cases where the provisions of the European Technical Approval and its control plan are no longer fulfilled the certification body shall withdraw the certificate of conformity and inform Deutsches Institut für Bautechnik without delay.

### 3.3 CE marking

The CE marking shall be affixed on each packaging of anchors. The letters "CE" shall be followed by the identification number of the approved certification body, where relevant, and be accompanied by the following additional information:

- the name and address of the producer (legal entity responsible for the manufacturer),
- the last two digits of the year in which the CE marking was affixed,
- the number of the EC certificate of conformity for the product,
- the number of the European Technical Approval,
- the number of the guideline for European Technical Approval,
- use category (ETAG 001-1, Option 7),
- size.

## 4 Assumptions under which the fitness of the product for the intended use was favourably assessed

### 4.1 Manufacturing

The anchor is manufactured in accordance with the provisions of the European Technical Approval using the automated manufacturing process as identified in the inspection of the plant by the Deutsches Institut für Bautechnik and the approved body and laid down in the technical documentation.

The European Technical Approval is issued for the product on the basis of agreed data/information, deposited with Deutsches Institut für Bautechnik, which identifies the product that has been assessed and judged. Changes to the product or production process, which could result in this deposited data/information being incorrect, should be notified to Deutsches Institut für Bautechnik before the changes are introduced. Deutsches Institut für Bautechnik will decide whether or not such changes affect the European Technical Approval and consequently the validity of the CE marking on the basis of the European Technical

Approval and if so whether further assessment or alterations to the European Technical Approval shall be necessary.

## 4.2 Installation

### 4.2.1 Design of anchorages

The fitness of the anchor for the intended use is given under the following conditions:

The anchorages are designed in accordance with the "Guideline for European Technical Approval of Metal Anchors for Use in Concrete", Annex C, Method A, for bonded anchors under the responsibility of an engineer experienced in anchorages and concrete work.

For the verifications given below according to Annex C the following shall be observed:

- For the verification 'concrete cone failure' (clause 5.2.2.4, Annex C of the Guideline)  $N_{Rk,c}$  shall be determined according to (1) and (2): The smaller of the values according to (1) and (2) is decisive.

(1)  $N_{Rk,c}$  according to equation (5.2), Annex C of the Guideline

where:

$$N_{Rk,c}^0 \quad \text{according to Annex 6}$$
$$S_{cr,N} \quad \text{according to Annex 6}$$
$$C_{cr,N} \quad \text{according to Annex 6}$$
$$\psi_{ucr,N} = 1,0$$

In special cases according to clause 5.2.2.4 g, Annex C of the Guideline the method given there is valid. However, the value  $N_{Rk,c}^0$  shall be calculated according to the following equation:

$$N_{Rk,c}^0 = N_{Rk,c}^0 \text{ (Annex 6)} \times \frac{h'_{ef}}{h_{ef}}$$

(2)  $N_{Rk,c}$  according to equation (5.2), Annex C of the Guideline

where:

$$N_{Rk,c}^0 = 0,75 \times 15,5 \times h_{ef}^{1,5} \times f_{ck,cube}^{0,5}$$
$$S_{cr,N} = 3 h_{ef}$$
$$C_{cr,N} = 1,5 h_{ef}$$
$$\psi_{ucr,N} = 1,0$$

For the verification 'splitting failure due to loading' (clause 5.2.2.6, Annex C of the Guideline)  $N_{Rk,sp}$  shall be determined according to (3).

(3)  $N_{Rk,sp}$  according to equation (5.3), Annex C of the Guideline

where:

$$N_{Rk,c}^0 \quad \text{according to Annex 6}$$
$$S_{cr,sp} \quad \text{according to Annex 6}$$
$$C_{cr,sp} \quad \text{according to Annex 6}$$
$$\psi_{ucr,N} = 1,0$$
$$\psi_{h,sp} = 1,0$$

- For the verification 'concrete pryout failure' (clause 5.2.3.3, Annex C of the Guideline)  $N_{Rk,c}$  for equation (5.6), Annex C of the Guideline, shall be determined according to (1).

Verifiable calculation notes and drawings are prepared taking account of the loads to be anchored.

The position of the anchor is indicated on the design drawings (e.g. position of the anchor relative to reinforcement or to supports, etc.).

### 4.2.2 Installation of anchors

The fitness for use of the anchor can only be assumed if the anchor is installed as follows:

- anchor installation carried out by appropriately qualified personnel and under the supervision of the person responsible for technical matters of the site,

- use of the anchor only as supplied by the manufacturer without exchanging the components of an anchor,
- anchor installation in accordance with the manufacturer's specifications and drawings using the tools indicated in the technical documentation of this European Technical Approval,
- checks before placing the anchor to ensure that the strength class of the concrete in which the anchor is to be placed is in the range given and is not lower than that of the concrete to which the characteristic loads apply,
- check of concrete being well compacted, e.g. without significant voids,
- keeping the effective anchorage depth,
- Edge distance and spacing not less than the specified values without minus tolerances,
- positioning of the drill holes without damaging the reinforcement,
- in case of aborted drill hole: the drill hole shall be filled with mortar,
- cleaning the drill hole by at least 2x blowing / 2x brushing / 2x blowing.
- the anchor component installation temperature shall be at least +5 °C;
- the temperature of the concrete during installation and curing of the chemical mortar must not fall below -5 °C;
- the curing time according to Annex 3 shall be observed before the anchor may be loaded,
- after the curing time fixing the member to be anchored by using a calibrated torque wrench by not exceeding the torque moment given in Annex 5.

## **5 Indications to the manufacturer**

### **5.1 Responsibility of the manufacturer**

The manufacturer is responsible to ensure that the information on the specific conditions according to 1 and 2 including Annexes referred to and 4.2.1 and 4.2.2 as well as 5.1 is given to those who are concerned. This information may be made by reproduction of the respective parts of the European Technical Approval. In addition all installation data shall be shown clearly on the package and/or on an enclosed instruction sheet, preferably using illustration(s).

The minimum data required are:

- drill bit diameter,
- hole depth,
- diameter of anchor rod,
- minimum effective anchorage depth,
- maximum thickness of the fixture,
- information on the installation procedure, including cleaning of the hole with the cleaning equipments, preferably by means of an illustration,
- anchor component installation temperature,
- ambient temperature of the concrete during installation of the anchor,
- admissible processing time (open time) of the mortar,
- curing time until the anchor may be loaded as a function of the ambient temperature in the concrete during installation,
- torque moment,
- identification of the manufacturing batch.

All data shall be presented in a clear and explicit form.

## **5.2 Packaging, transport and storage**

The injection cartridges shall be protected against sun radiation and shall be stored according to the manufacturer's installation instructions in dry condition at temperatures of at least +5 °C to not more than +25 °C.

Mortar cartridges with expired shelf life must no longer be used.

The anchor shall only be packaged and supplied as a complete unit. Mortar cartridges may be packed separately from anchor rods, nuts and washers.

The manufacturer's installation instruction shall indicate that the injection mortar MKT Injection Adhesive VMU shall be used with the corresponding anchor rods of the manufacturer according to Annex 2.

Dipl.-Ing. E. Jasch

*beglaubigt:*

Lange

## Injection System VMU

### Sealing cap



### Mortar cartridge

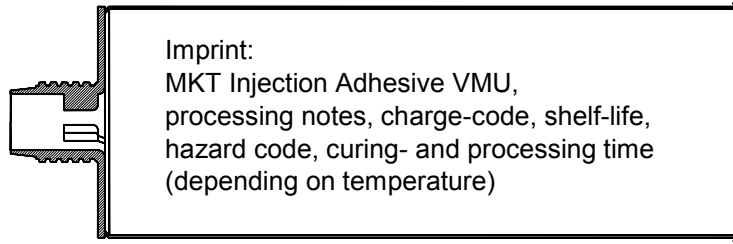

### Static mixer

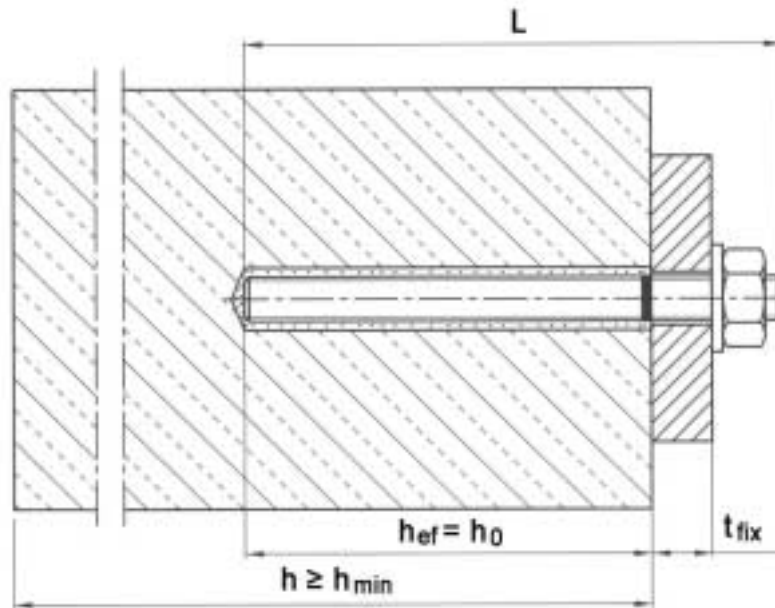
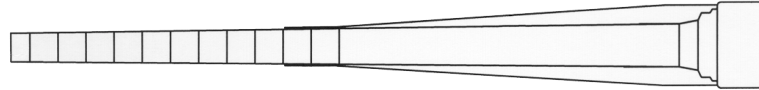

Use category: Installation in dry or wet concrete, or flooded hole  
Service in dry internal conditions

Temperature range: - 40°C to + 80°C (max short term temperature + 80°C and  
max long term temperature + 50°C)  
- 40°C to + 120°C (max short term temperature + 120°C and  
max long term temperature + 72°C)

**MKT Injection System VMU for concrete**

**Product and intended use**

**Annex 1**

of European  
Technical Approval

**ETA-05/0253**

**Anchor rod VMU-A, Anchor rod VMU-A fvz**

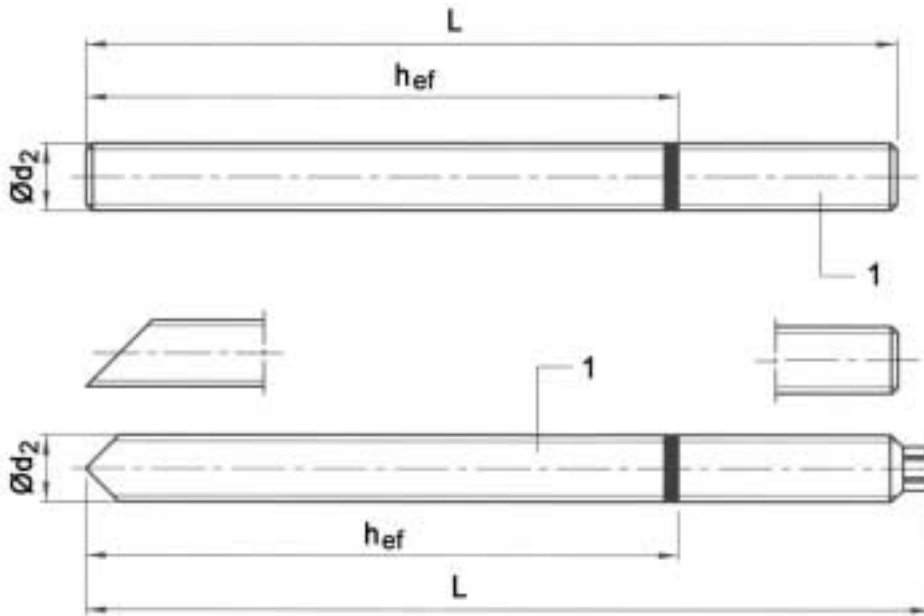

Marking: e.g.

- ◇ M12
- ◇ Identifying mark of manufacturing plant
- additional marking of lengths for anchor size M12
- H marking of length
- M12 Size of thread

- ◇ M12-8
- 8 additional marking of steel grade 8.8

Marking of length	F	G	H	I	J	K	L	M
Length of anchor min $\geq$	101,6	114,3	127,0	139,7	152,4	165,1	177,8	190,5
Length of anchor max $<$	114,3	127,0	139,7	152,4	165,1	177,8	190,5	203,2



Marking of length	N	O	P	Q	R	S	T	U	V	W	X	Y	Z
Length of anchor min $\geq$	203,2	215,9	228,6	241,3	254,0	279,4	304,8	330,2	355,6	381,0	406,4	431,8	457,2
Length of anchor max $<$	215,9	228,6	241,3	254,0	279,4	304,8	330,2	355,6	381,0	406,4	431,8	457,2	483,0

Dimensions in mm

**Table 1: Anchor dimensions**

Size	Anchor rod		
	$\varnothing d_2$ [mm]	$h_{ef}$ [mm]	min L <sup>1)</sup> [mm]
M10	10	90	$\geq 101$
M12	12	110	$\geq 124$
M16	16	125	$\geq 143$

<sup>1)</sup> max L = 1500 mm

<b>MKT Injection System VMU for concrete</b>	<b>Annex 2</b> of European Technical Approval  <b>ETA-05/0253</b>
<b>Anchor dimensions</b>	

**Table 2: Materials**

Part	Designation	Steel, zinc plated $\geq 5 \mu\text{m}$ acc. to EN ISO 4042	Steel, hot dipped galvanised $\geq 40 \mu\text{m}$ acc. to EN ISO 1461
1	Anchor rod	Anchor rod VMU-A Steel, acc. to EN ISO 898-1, steel grade 5.8, 8.8	Anchor rod VMU-A fvz Steel, acc. to EN ISO 898-1, steel grade 5.8, 8.8
2	Hexagon nut according to DIN 934	Strength class 8 acc. to EN 20 898-2, galvanised	Strength class 8 acc. to EN 20 898-2, hot dipped galvanised
3	Washer	Steel, galvanised	Steel, hot dipped galvanised
4	Mortar cartridge	Vinylester resin, styrene free	

**Table 3: Minimum curing time**

Temperature [°C] in the drill hole	Maximum processing time [minutes]	Minimum curing time [minutes]	
		dry concrete	wet concrete
+ 40 °C	1.4	15	30
+ 35 °C	2	20	40
+ 30 °C	4	25	50
+ 20 °C	6	45	90
+ 10 °C	12	80	160
+ 5 °C	20	120	240
0 °C	45	180	360
- 5 °C	90	330	660

**MKT Injection System VMU for concrete**

**Materials,  
Curing times depending on the temperature**

**Annex 3**

of European  
Technical Approval

**ETA-05/0253**

**Mortar cartridges VMU**  
(different container sizes)

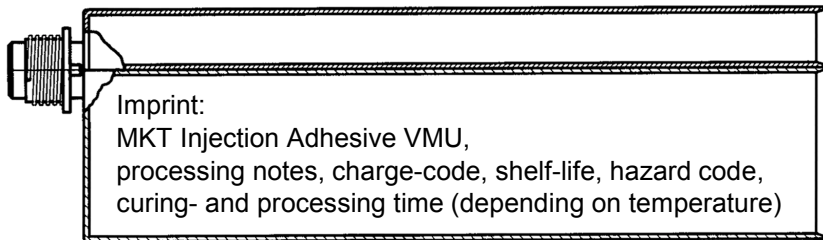
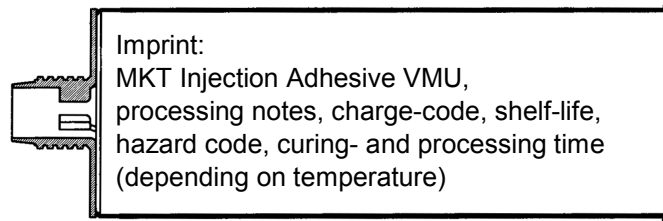

**Sealing cap**



**Static mixer**

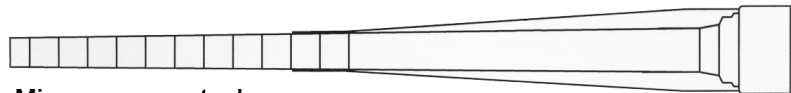

Mixer, one-way tool,  
must be changed in case of working interruption

**MKT Injection System VMU for concrete**

**Mortar cartridges**

**Annex 4**

of European  
Technical Approval

**ETA-05/0253**

**Table 4: Installation parameters**

Anchor size		M10	M12	M16
Nominal diameter of drill hole	$d_0 =$ [mm]	12	14	18
Cutting diameter of drill hole	$d_{cut} \leq$ [mm]	12.5	14.5	18.5
Depth of drill hole	$h_0 \geq$ [mm]	90	110	125
Diameter of clearance hole in the fixture	$d_f \leq$ [mm]	12	14	18
Diameter of steel brush	$D \geq$ [mm]	13	15	19
Torque moment	$T_{inst} =$ [Nm]	20	40	60
Thickness of fixture	$\min t_{fix} >$ [mm]	0		
	$\max t_{fix} <$ [mm]	1399	1376	1357
Effective anchorage depth	$h_{ef} =$ [mm]	90	110	125
Minimum thickness of concrete	$h_{min} =$ [mm]	130	160	200
Reduced Minimum thickness of concrete	$h_{min,red} =$ [mm]	120	140	160
Minimum spacing	$s_{min} =$ [mm]	45	55	65
Minimum edge distance	$c_{min} =$ [mm]	45	55	65

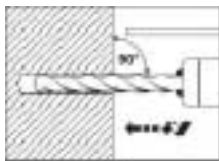
**Steel brush****Installation**

Drilling

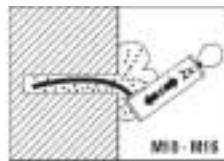

2x blowing,

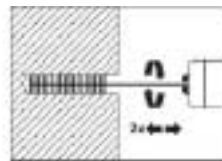

2x brushing,

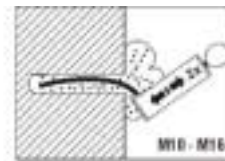

2x blowing

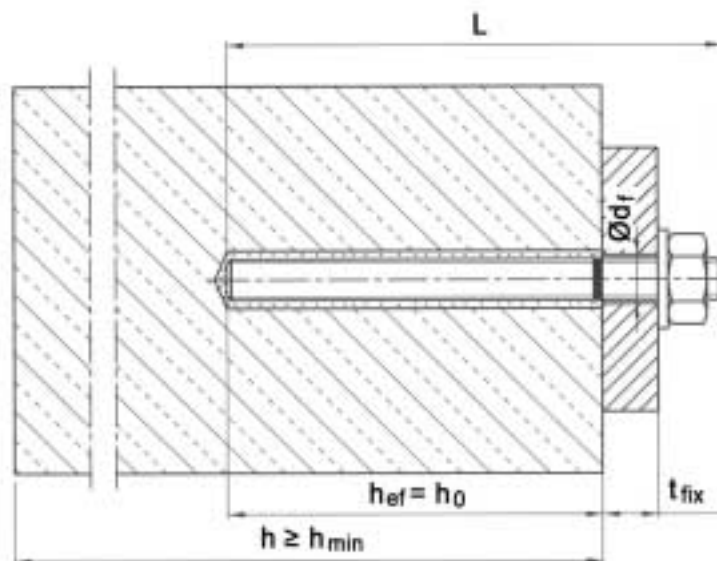
**MKT Injection System VMU for concrete****Installation parameters****Annex 5**of European  
Technical Approval**ETA-05/0253**

**Table 5: Design method A**  
**Characteristic values for tension loads**

Anchor size			M10	M12	M16
<b>Steel failure</b>					
Characteristic tension resistance, steel grade 5.8	$N_{Rk,s}$	[kN]	29	42.1	78.3
Characteristic tension resistance, steel grade 8.8	$N_{Rk,s}$	[kN]	46.4	67.4	126
Partial safety factor	$\gamma_{Ms}$ <sup>1)</sup>	-	1.5		
<b>Pullout and concrete cone failure</b>					
Effective anchorage depth	$h_{ef}$	[mm]	90	110	125
Non-cracked concrete C20/25 (50°C / 80°C) <sup>4)</sup>	$N_{Rk,c}^0 = N_{Rk,p}$	[kN]	25	35	50
Non-cracked concrete C20/25 (72°C / 120°C) <sup>4)</sup>	$N_{Rk,c}^0 = N_{Rk,p}$	[kN]	16	25	40
Increasing factors for non-cracked concrete $\psi_c$	C30/37	-	1.12		
	C40/50	-	1.23		
	C50/60	-	1.30		
Characteristic edge distance	$c_{cr,N}$	[mm]	90	110	125
Characteristic spacing	$s_{cr,N}$	[mm]	180	220	250
Partial safety factor	$\gamma_{Mc} = \gamma_{Mp}$ <sup>1) 2)</sup>	-	1.5 / 1.8 <sup>3)</sup>	1.5	1.5
<b>Splitting failure</b>					
Standard minimum thickness of concrete slab	$h_{min}$	[mm]	130	160	200
Edge distance	$c_{cr,sp}$	[mm]	90	110	125
Spacing	$s_{cr,sp}$	[mm]	180	220	250
reduced minimum thickness of concrete slab	$h_{min,red}$	[mm]	120	140	160
Edge distance	$c_{cr,sp}$	[mm]	145	180	200
Spacing	$s_{cr,sp}$	[mm]	290	360	400
Partial safety factor	$\gamma_{Msp}$ <sup>1) 2)</sup>	-	1.5 / 1.8 <sup>3)</sup>	1.5	1.5

1) In absence of other national regulations

2) The partial safety factor  $\gamma_2 = 1.0$  is included

3) M10:  $\gamma_{Mc} = \gamma_{Mp} = 1.5$  in dry and wet concrete,  $\gamma_{Mc} = \gamma_{Mp} = 1.8$  in flooded hole.

4) Maximum long term temperature / maximum short term temperature

**Table 6: Displacements under tension loads**

Anchor size			M 10	M12	M16
Tension load	N	[kN]	11.9	16.7	23.8
Displacement	$\delta_{N0}$	[mm]	0.1	0.1	0.1
	$\delta_{N\infty}$	[mm]	0.2		

**MKT Injection System VMU for concrete**

**Design Method A**  
**Characteristic values for tension loads,**  
**Displacements**

**Annex 6**

of European  
Technical Approval

**ETA-05/0253**

**Table 7: Design method A**  
**Characteristic values for shear loads**

Anchor size			M10	M12	M16
<b>Steel failure without lever arm</b>					
Characteristic shear resistance, steel grade 5.8	$V_{Rk,s}$	[kN]	14.5	21.1	39.2
Characteristic shear resistance, steel grade 8.8	$V_{Rk,s}$	[kN]	23.2	33.7	63
Partial safety factor	$\gamma_{Ms}^{1)}$	-	1.25		
<b>Steel failure with lever arm</b>					
Characteristic bending moments, steel grade 5.8	$M_{Rk,s}^0$	[Nm]	37.5	65	165
Characteristic bending moments, steel grade 8.8	$M_{Rk,s}^0$	[Nm]	60	105	266
Partial safety factor	$\gamma_{Ms}^{1)}$	-	1.25		
<b>Concrete pryout failure</b>					
Factor in equation (5.6) ETAG Annex C, 5.2.3.3	k	-	2		
Partial safety factor	$\gamma_{Mc}^{1)}$	-	1.5 <sup>2)</sup>		
<b>Concrete edge failure</b>					
Effective length of anchor in shear loading	$l_f$	[mm]	90	110	125
Diameter of anchor	$d_{nom}$	[mm]	12	14	18
Partial safety factor	$\gamma_{Mc}^{1)}$	-	1.5 <sup>2)</sup>		

1) In absence of other national regulations

2) The partial safety factor  $\gamma_2 = 1.0$  is included

**Table 8: Displacements under shear loads**

Anchor size			M10	M12	M16
Shear load, steel grade 5.8	V	[kN]	8.3	12.1	22.4
Displacement	$\delta_{V0}$	[mm]	0.4	0.8	1.2
	$\delta_{V\infty}$	[mm]	0.7	1.2	1.8
Shear load, steel grade 8.8	V	[kN]	13.2	19.3	35.9
Displacement	$\delta_{V0}$	[mm]	0.7	1.2	1.9
	$\delta_{V\infty}$	[mm]	1.1	1.9	2.8

**MKT Injection System VMU for concrete**

**Design Method A**  
**Characteristic values for shear loads,**  
**Displacements**

**Annex 7**

of European  
 Technical Approval

**ETA-05/0253**