

Deutsches Institut für Bautechnik

Anstalt des öffentlichen Rechts

Kolonnenstr. 30 L
10829 Berlin
Germany

Tel.: +49(0)30 787 30 0
Fax: +49(0)30 787 30 320
E-mail: dibt@dibt.de
Internet: www.dibt.de

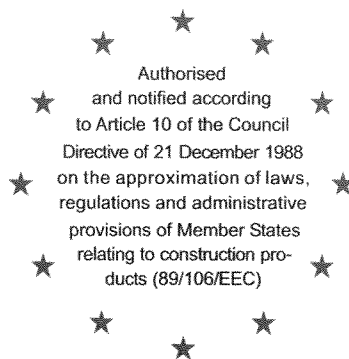

DIBt

Mitglied der EOTA
Member of EOTA

European Technical Approval ETA-05/0116

English translation prepared by DIBt - Original version in German language

Handelsbezeichnung
Trade name

MKT Einschlaganker E
MKT Drop-in Anchor E

Zulassungsinhaber
Holder of approval

MKT
Metall-Kunststoff-Technik GmbH & Co. KG
Auf dem Immel 2
67685 Weilerbach

**Zulassungsgegenstand
und Verwendungszweck**

Wegkontrolliert spreizender Dübel aus galvanisch verzinktem Stahl in den Größen M6, M8, M10 und M12 für die Verwendung als Mehrfachbefestigung von nichttragenden Systemen in Beton

*Generic type and use
of construction product*

Deformation-controlled expansion anchor made of galvanised steel of sizes M6, M8, M10 and M12 for multiple use for non-structural applications in concrete

Geltungsdauer: vom
Validity: from
bis
to

24. August 2005
24. August 2010

Herstellwerk
Manufacturing plant

MKT
Metall-Kunststoff-Technik GmbH & Co. KG
Auf dem Immel 2
67685 Weilerbach

Diese Zulassung umfasst
This Approval contains

12 Seiten einschließlich 5 Anhänge
12 pages including 5 annexes



Europäische Organisation für Technische Zulassungen
European Organisation for Technical Approvals

I LEGAL BASES AND GENERAL CONDITIONS

- 1 This European Technical Approval is issued by Deutsches Institut für Bautechnik in accordance with:
 - Council Directive 89/106/EEC of 21 December 1988 on the approximation of laws, regulations and administrative provisions of Member States relating to construction products¹, modified by Council Directive 93/68/EEC² and Regulation (EC) N° 1882/2003 of the European Parliament and of the Council³;
 - Gesetz über das In-Verkehr-Bringen von und den freien Warenverkehr mit Bauprodukten zur Umsetzung der Richtlinie 89/106/EWG des Rates vom 21. Dezember 1988 zur Angleichung der Rechts- und Verwaltungsvorschriften der Mitgliedstaaten über Bauprodukte und anderer Rechtsakte der Europäischen Gemeinschaften (Bauproduktengesetz - BauPG) vom 28. April 1998⁴, zuletzt geändert durch Gesetz vom 06.01.2004⁵;
 - Common Procedural Rules for Requesting, Preparing and the Granting of European Technical Approvals set out in the Annex to Commission Decision 94/23/EC⁶;
 - Guideline for European Technical Approval "Metal anchors for use in concrete - Part 6: Anchors for multiple use for non-structural applications", ETAG 001-06.
- 2 Deutsches Institut für Bautechnik is authorized to check whether the provisions of this European Technical Approval are met. Checking may take place in the manufacturing plant. Nevertheless, the responsibility for the conformity of the products to the European Technical Approval and for their fitness for the intended use remains with the holder of the European Technical Approval.
- 3 This European Technical Approval is not to be transferred to manufacturers or agents of manufacturers other than those indicated on page 1, or manufacturing plants other than those indicated on page 1 of this European Technical Approval.
- 4 This European Technical Approval may be withdrawn by Deutsches Institut für Bautechnik, in particular pursuant to information by the Commission according to Article 5(1) of Council Directive 89/106/EEC.
- 5 Reproduction of this European Technical Approval including transmission by electronic means shall be in full. However, partial reproduction can be made with the written consent of Deutsches Institut für Bautechnik. In this case partial reproduction has to be designated as such. Texts and drawings of advertising brochures shall not contradict or misuse the European Technical Approval.
- 6 The European Technical Approval is issued by the approval body in its official language. This version corresponds fully to the version circulated in EOTA. Translations into other languages have to be designated as such.

1 Official Journal of the European Communities N° L 40, 11.2.1989, p. 12
2 Official Journal of the European Communities N° L 220, 30.8.1993, p. 1
3 Official Journal of the European Union N° L 284, 31.10.2003, p. 25
4 Bundesgesetzblatt I, p. 812
5 Bundesgesetzblatt I, p.2, 15
6 Official Journal of the European Communities N° L 17, 20.1.1994, p. 34

II SPECIFIC CONDITIONS OF THE EUROPEAN TECHNICAL APPROVAL

1 Definition of the construction product and intended use

1.1 Definition of the product

The MKT Drop-in Anchor E of sizes M6, M8, M8x40, M10 and M12 is an anchor made of galvanised steel which is placed into a drilled hole and anchored by deformation-controlled expansion.

An illustration of the installed anchor is given in Annex 1.

The fixture shall be anchored with a fastening screw or threaded rod according to Annex 4.

1.2 Intended use

The anchor is intended to be used for anchorages for which requirements for safety in use in the sense of the Essential Requirements 4 of Council Directive 89/106 EEC shall be fulfilled and failure of the fixture represents an immediate risk to human life. The anchor is to be used only for multiple use for non-structural applications. The definition of multiple use according to the Member States is given in the informative Annex 1 of ETAG 001, Part 6.

The anchor may be used for anchorages with requirements related to resistance to fire.

The anchor is to be used only for anchorages subject to static or quasi-static loading in reinforced or unreinforced normal weight concrete of strength classes C20/25 at minimum and C50/60 at most according to EN 206-1:2000-12. It may be anchored in cracked or non-cracked concrete.

The anchor may only be used in structures subject to dry internal conditions.

The provisions made in this European Technical Approval are based on an assumed working life of the anchor of 50 years. The indications given on the working life cannot be interpreted as a guarantee given by the producer, but are to be regarded only as a means for choosing the right products in relation to the expected economically reasonable working life of the works.

2 Characteristics of product and methods of verification

2.1 Characteristics of product

The anchor corresponds to the drawings and provisions given in Annex 2. The characteristic material values, dimensions and tolerances of the anchor not given in Annex 2 shall correspond to the respective values laid down in the technical documentation⁷ of this European Technical Approval.

Regarding the requirements concerning safety in case of fire it is assumed that the anchor meets the requirements of class A1 in relation to reaction to fire in accordance with the stipulations of the Commission decision 96/603/EC, amended by 2000/605/EC.

The fastening screw or threaded rod shall correspond at least to the strength class 4.6 according to EN ISO 898-1.

The characteristic values for the design of anchorages are given in Annex 5, Table 5. The characteristic anchor values for the design of the anchorages regarding resistance to fire are given in Annex 5, Table 6. They are valid for use in a system that is required to provide a specific fire resistance class.

⁷

The technical documentation of this European Technical Approval is deposited at the Deutsches Institut für Bautechnik and, as far as relevant for the tasks of the approved bodies involved in the attestation of conformity procedure, is handed over to the approved bodies.

In addition to the specific clauses relating to dangerous substances contained in this European Technical Approval, there may be other requirements applicable to the products falling within its scope (e.g. transposed European legislation and national laws, regulations and administrative provisions). In order to meet the provisions of the Construction Products Directive, these requirements need also to be complied with, when and where they apply.

Each anchor is marked with the identifying mark of the producer including the anchor type and the thread size according to Annex 2.

In addition, the expansion sleeve for anchor size M8 x 40 is marked on the top of the sleeve.

The anchor shall only be packaged and supplied as a complete unit.

2.2 Methods of verification

The assessment of fitness of the anchor for the intended use in relation to the requirements for safety in use in the sense of the Essential Requirements 4 has been made in accordance with the "Guideline for European Technical Approval of Metal Anchors for Use in Concrete", Part 1 "Anchors in general" and Part 6 "Anchors for multiple use for non-structural applications".

The assessment of the anchor for the intended use in relation to the requirements for resistance to fire has been made in accordance with the Technical Report TR 020 "Evaluation of anchorages in concrete concerning resistance to fire".

3 Evaluation and attestation of conformity and CE marking

3.1 System of attestation of conformity

According to the decision 97/161/EG of the European Commission⁸ the system 2(ii) (referred to as system 2+) of attestation of conformity applies.

This system of attestation of conformity is defined as follows:

System 2+: Declaration of conformity of the product by the manufacturer on the basis of:

(a) Tasks for the manufacturer:

- (1) initial type-testing of the product;
- (2) factory production control;
- (3) testing of samples taken at the factory in accordance with a prescribed test plan.

(b) Tasks for the approved body:

- (4) certification of factory production control on the basis of:
 - initial inspection of factory and of factory production control;
 - continuous surveillance, assessment and approval of factory production control.

3.2 Responsibilities

3.2.1 Tasks of the manufacturer

3.2.1.1 Factory production control

The manufacturer shall exercise permanent internal control of production. All the elements, requirements and provisions adopted by the manufacturer shall be documented in a systematic manner in the form of written policies and procedures, including records of results performed. This production control system shall insure that the product is in conformity with this European Technical Approval.

The manufacturer may only use initial / raw / constituent materials stated in the technical documentation of this European Technical Approval.

8 Official Journal of the European Communities L 67 of 03.02.1997

The factory production control shall be in accordance with the control plan relating to this European Technical Approval of February 2004 which is part of the technical documentation of this European Technical Approval. The control plan is laid down in the context of the factory production control system operated by the manufacturer and deposited at Deutsches Institut für Bautechnik.⁹

The results of factory production control shall be recorded and evaluated in accordance with the provisions of the control plan.

3.2.1.2 Other tasks of manufacturer

The manufacturer shall, on the basis of a contract, involve a body which is approved for the tasks referred to in section 3.1 in the field of the anchor in order to undertake the actions laid down in section 3.3. For this purpose, the control plan referred to in sections 3.2.1.1 and 3.2.2 shall be handed over by the manufacturer to the approved body involved.

The manufacturer shall make a declaration of conformity, stating that the construction product is in conformity with the provisions of this European Technical Approval.

3.2.2 Tasks of approved bodies

The approved body shall perform the

- initial inspection of factory and of factory production control,
- continuous surveillance, assessment and approval of factory production control.

in accordance with the provisions laid down in the control plan relating to this European Technical Approval.

The approved body shall retain the essential points of its actions referred to above and state the results obtained and conclusions drawn in a written report.

The approved certification body involved by the manufacturer shall issue an EC certificate of conformity of the factory production control stating the conformity with the provisions of this European Technical Approval.

In cases where the provisions of the European Technical Approval and its control plan are no longer fulfilled the certification body shall withdraw the certificate of conformity and inform Deutsches Institut für Bautechnik without delay.

3.3 CE marking

The CE marking shall be affixed on each packing of the anchor. The letters "CE" shall be followed by the identification number of the approved certification body, where relevant, and be accompanied by the following additional information:

- the name and address of the producer (legal entity responsible for the manufacture),
- the last two digits of the year in which the CE marking was affixed,
- the number of the EC certificate for the factory production,
- the number of the European Technical Approval,
- the number of the guideline for European Technical Approval,
- use category (ETAG 001-6),
- size.

⁹

The control plan is a confidential part of the European Technical Approval and only handed over to the approved body involved in the procedure of attestation of conformity. See section 3.2.2.

4 Assumptions under which the fitness of the product for the intended use was favourably assessed

4.1 Manufacturing

The European Technical Approval is issued for the product on the basis of agreed data/information, deposited with Deutsches Institut für Bautechnik, which identifies the product that has been assessed and judged. Changes to the product or production process, which could result in this deposited data/information being incorrect, should be notified to Deutsches Institut für Bautechnik before the changes are introduced. Deutsches Institut für Bautechnik will decide whether or not such changes affect the European Technical Approval and consequently the validity of the CE marking on the basis of the European Technical Approval and if so whether further assessment or alterations to the European Technical Approval shall be necessary.

4.2 Installation

4.2.1 Design of anchorages

The fitness of the anchor for the intended use is given under the following conditions:

The anchorages are designed in accordance with the "Guideline for European Technical Approval of Metal Anchors for Use in Concrete", Annex C, Method B, for deformation-controlled expansion anchors under the responsibility of an engineer experienced in anchorages and concrete work.

Verifiable calculation notes and drawings are prepared taking account of the loads to be anchored.

The position of the anchor is indicated on the design drawings (e.g. position of the anchor relative to reinforcement or to supports).

The minimum strength class and the minimum screwing depth of the fastening screw or threaded rod for installation of the fixture shall be met the requirements according to Annex 4. The length of the fastening screw or threaded rod shall be defined according to the available thread length, the minimum screwing depth, the thickness of fixture and tolerances of member and fixture.

The design of anchorages under fire exposure has to consider the conditions given in the Technical Report TR 020 "Evaluation of anchorages in concrete concerning resistance to fire". The relevant characteristic values are given in Annex 5, Table 6. The design method covers anchors with a fire attack from one side only. If the fire attack is from more than one side, the design method may be taken only, if the edge distance of the anchor is $c \geq 300$ mm.

4.2.2 Installation of anchors

The fitness for use of the anchor can only be assumed if the anchor is installed as follows:

- Anchor installation carried out by appropriately qualified personnel and under the supervision of the person responsible for technical matters of the site.
- Use of the anchor only as supplied by the manufacturer without exchanging the components of an anchor.
- Anchor installation in accordance with the manufacturer's specifications and drawings and using the appropriate tools.
- Checks before placing the anchor to ensure that the strength class of the concrete in which the anchor is to be placed is in the range given and is not lower than that of the concrete to which the characteristic loads apply.
- Check of concrete being well compacted, e.g. without significant voids.
- Edge distances and spacings not less than the specified values without minus tolerances.
- Positioning of the drill holes without damaging the reinforcement.

- In case of aborted hole: new drilling at a minimum distance away of twice the depth of the aborted hole or smaller distance if the aborted drill hole is filled with high strength mortar and if under shear or oblique tension load it is not in the direction of load application.
- Cleaning of the drill hole.
- Anchor installation such that the effective setting depth is complied with. This compliance is ensured, if the expansion sleeve does not exceed the concrete surface.
- Anchor expansion by impact on the cone using the setting tools given in Annex 3. The anchor is properly set if the stop of the pin reaches the expansion sleeve and the impression of the setting tool for marking is visible as illustrated in Annex 3.
- The fastening screw or threaded rod shall correspond to the requirements given in Annex 4.
- Application of the torque moment given in Annex 4 using a calibrated torque wrench.

4.2.3 Responsibility of the manufacturer

The manufacturer is responsible to ensure that the information on the specific conditions according to 1 and 2 including Annexes referred to and 4.2.1 and 4.2.2 is given to those who are concerned. This information may be made by reproduction of the respective parts of the European Technical Approval. In addition all installation data shall be shown clearly on the package and/or on an enclosed instruction sheet, preferably using illustration(s).

The minimum data required are:

- drill bit diameter,
- thread diameter,
- minimum effective anchorage depth,
- available thread length and minimum screwing depth of the fastening screw or threaded rod,
- minimum strength class of the fastening screw or threaded rod according to EN ISO 898-1
- minimum hole depth,
- torque moment,
- information on the installation procedure, including cleaning of the hole, preferably by means of an illustration,
- reference to any special installation equipment needed,
- identification of the manufacturing batch.

All data shall be presented in a clear and explicit form.

Dipl.-Ing. Erich Jasch

Beglaubigt:
Lange

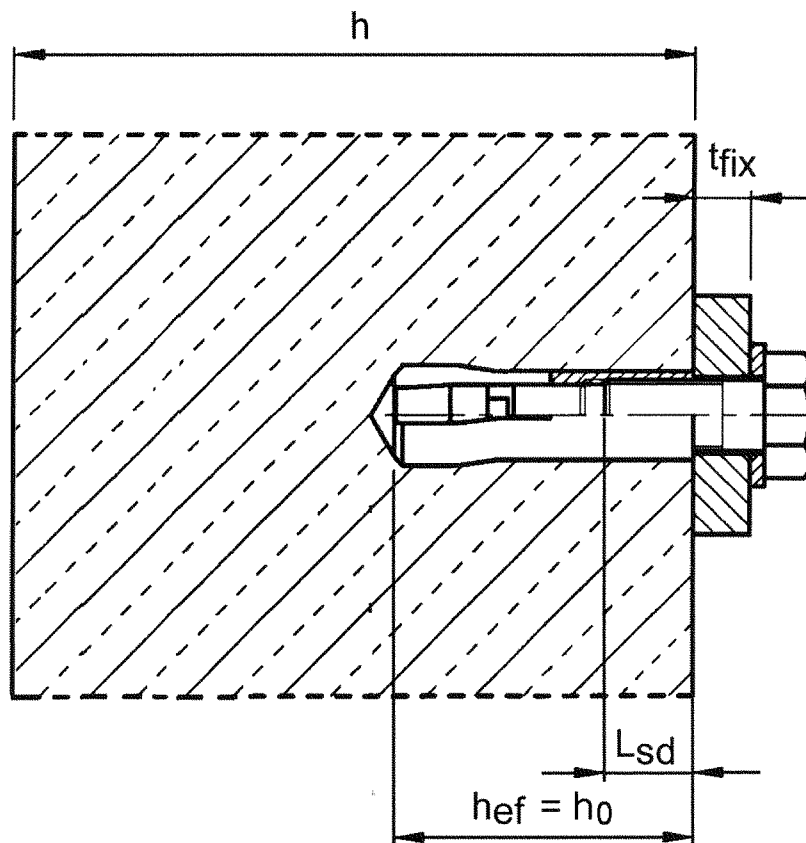
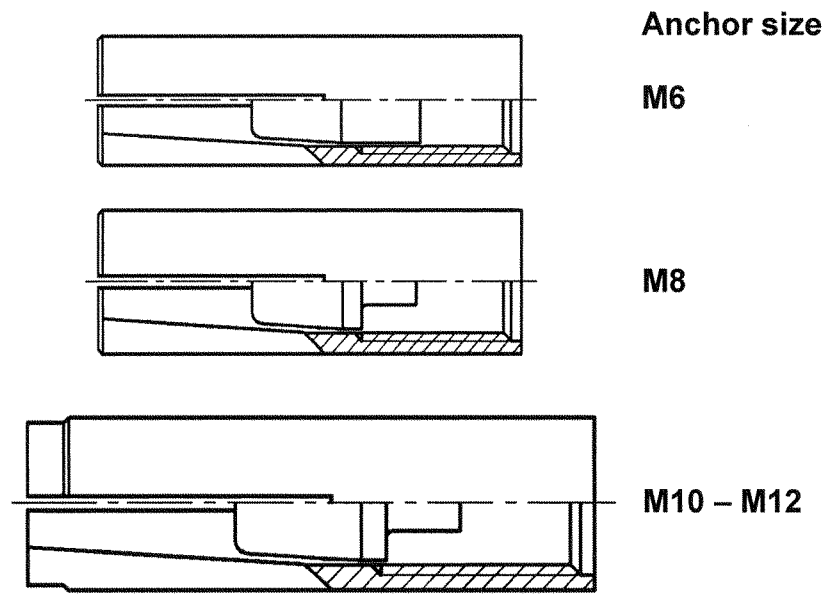

MKT Drop-in Anchor E

Product and intended use

Annex 1

of European
Technical Approval



ETA-05/0116

Expansion sleeve

Anchor size M8x40:

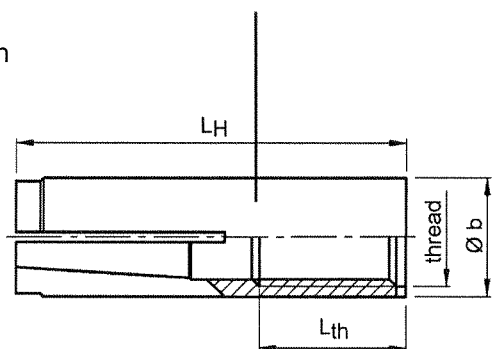
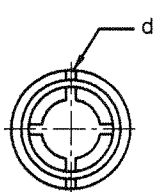
additional marking d,
visible after installation



Marking: e.g.:  E M8
 Identifying mark
 of manufacturing plant 
 Anchor identity
 E
 Size of thread
 M 8

Cone Anchor size M6

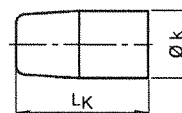

Anchor sizes M8–M12

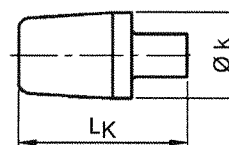

Table 1: Dimensions

Anchor size	expansion sleeve				cone	
	M	Ø b	L _H	L _{th}	Ø k	L _K
M6	M6	8	30	13	5.0	13
M8	M8	10	30	13		
M8x40	M8	10	40	20	8.2	16
M10	M10	12	40	15		
M12	M12	15	50	18		

Table 2: Designation of and materials

Part	Designation	materials, zinc coated ≥ 5 µm, acc. to EN ISO 4042
1	expansion sleeve	free-cutting steel acc. to EN 10 087
2	cone	steel for cold forming acc. to EN 10 263

MKT Drop-in Anchor E

**Dimensions,
Designations of and materials**

Annex 2

of European
Technical Approval

ETA-05/0116

Setting tool for marking

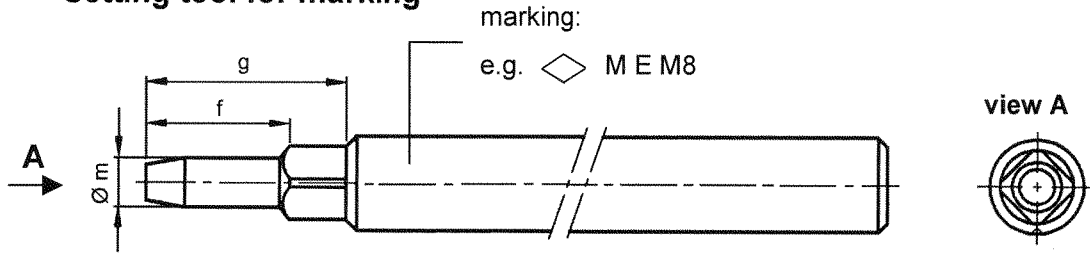

Verification of correct installation with setting tool marking

The setting tool leaves a visible impression after correct installation.

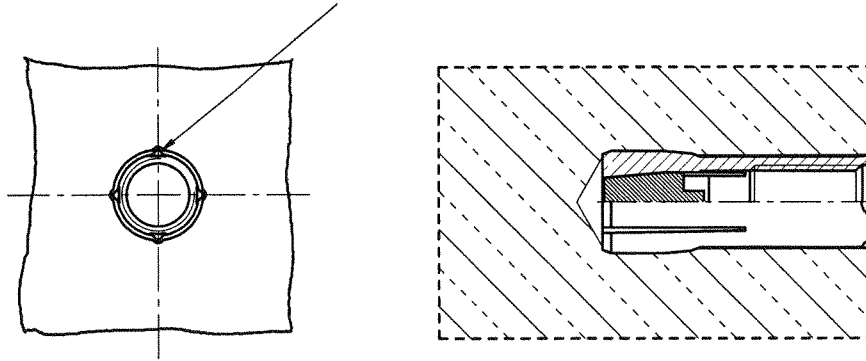

Setting tool

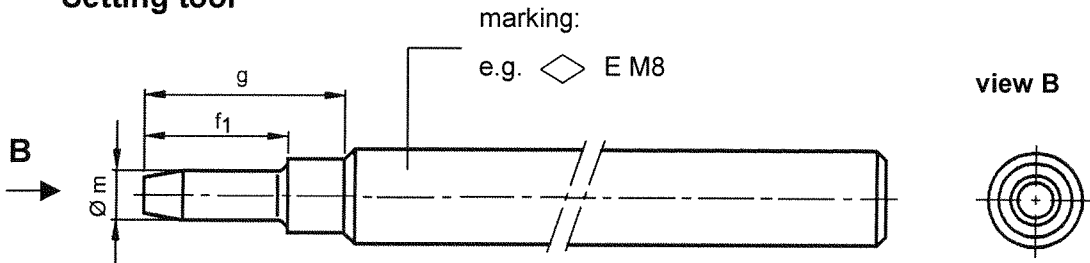

Table 3: Dimensions of setting tools

Anchor size	Ø m	f	f ₁	g
M6	4.9	-	17	27
M8	6.4	18.2	18	28
M8 x 40	6.4	28.2	28	38
M10	8.0	24.2	24	34
M12	10.0	30.4	30	40

MKT Drop-in Anchor E

Dimensions of setting tools and verification of correct installation

Annex 3

of European
Technical Approval

ETA-05/0116

Table 4: Installation parameters

Anchor size		M6	M8	M8x40	M10	M12
Drill hole diameter	$d_0 =$ [mm]	8	10	10	12	15
Cutting diameter of drill bit	$d_{cut} \leq$ [mm]	8.45	10.45	10.45	12.5	15.5
Depth of drill hole	h_0 [mm]	30	30	40	40	50
Recommended setting torque	$T_{inst} =$ [Nm]	4	8	8	15	35
Diameter of clearance hole in the fixture	$d_f \leq$ [mm]	7	9	9	12	14
Available thread length	L_{th} [mm]	13	13	20	15	18
Minimum screwing depth	L_{sdmin} [mm]	7	9	9	11	13
Minimum thickness of member	h_{min} [mm]	100	100	100	120	130
Minimum spacing and edge distance	s_{min} [mm]	55	60	80	100	120
	c_{min} [mm]	95	95	95	135	165
Characteristic spacing and edge distance	s_{cr} [mm]	130	180	210	170	170
	c_{cr} [mm]	65	90	105	85	85

For use in a fire resistance class see Annex 5

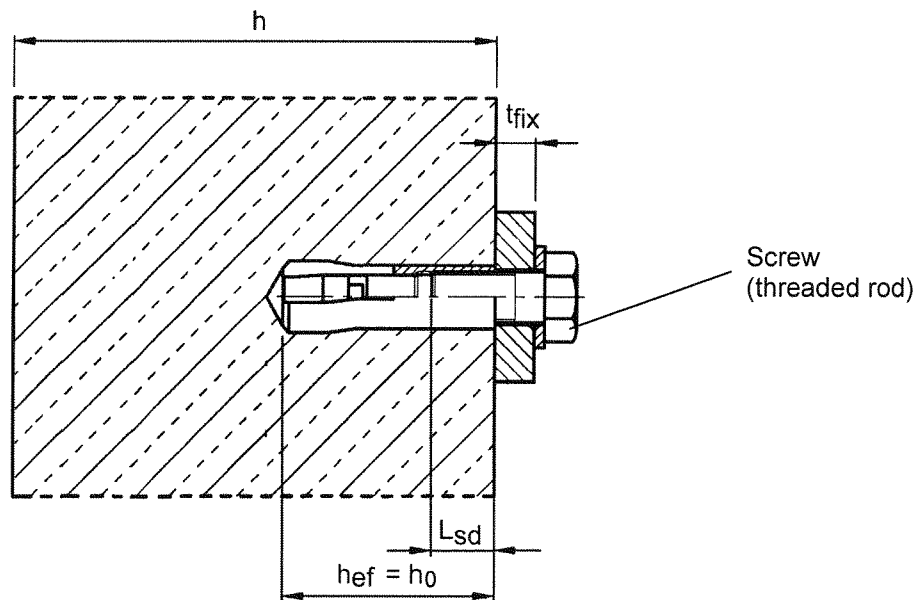

Requirements for the fastening screw or threaded rod:

- Minimum strength class 4.6 acc. to EN ISO 898-1;
- Minimum screwing depth L_{sdmin} see Table 4;
- The length of the fastening screw shall be determined on thickness of fixture t_{fix} , admissible tolerances, available thread length L_{th} (= maximum screwing depth) and minimum screwing depth L_{sdmin} .

MKT Drop-in Anchor E

Installation parameters

Annex 4

of European
Technical Approval

ETA-05/0116

Table 5: Design method B – Characteristic values of resistance

Anchor size			M6	M8	M8x40	M10	M12
In any load direction							
Characteristic resistance in concrete C20/25 to C50/60	F_{Rk}	[kN]	3	5	6	6	6
Partial safety factor	$\gamma_M^{1)}$		1.8 ²⁾	2.16 ²⁾			1.8 ²⁾
Shear load with lever arm							
Characteristic resistance (Steel 4.6)	$M_{Rk,s}^0$ ³⁾	[Nm]	6.1	15	15	30	52
Partial safety factor	$\gamma_{Ms}^{1)}$	[-]	1.67				
Characteristic resistance (Steel 5.6)	$M_{Rk,s}^0$ ³⁾	[Nm]	7.6	19	19	37	65
Partial safety factor	$\gamma_{Ms}^{1)}$	[-]	1.67				
Characteristic resistance (Steel 5.8)	$M_{Rk,s}^0$ ³⁾	[Nm]	7.6	19	19	37	65
Partial safety factor	$\gamma_{Ms}^{1)}$	[-]	1.25				
Characteristic resistance (Steel 8.8)	$M_{Rk,s}^0$ ³⁾	[Nm]	12	30	30	60	105
Partial safety factor	$\gamma_{Ms}^{1)}$	[-]	1.25				

¹⁾ In absence of other national regulations

²⁾ The partial safety factor γ_2 is included

³⁾ Characteristic bending moment $M_{Rk,s}^0$ for equation (5.5) in ETAG 001, Annex C

The anchor is to be used only for multiple use for non-structural applications, the definition of multiple use according to the Member States is given in the informative Annex 1 of ETAG 001, Part 6.

Table 6: Characteristic values under fire exposure in concrete C20/25 to C50/60

Anchor size			M6	M8	M8x40	M10	M12	
Fire resistance class	In any load direction							
	Characteristic resistance	$F_{Rk,fi}^{1)}$	[kN]	0.8	0.9	0.9	1.5	1.5
R 30	Characteristic resistance	$F_{Rk,fi}^{1)}$	[kN]	0.8	0.9	0.9	1.5	1.5
R 60	Characteristic resistance	$F_{Rk,fi}^{1)}$	[kN]	0.4	0.9	0.9	1.5	1.5
R 90	Characteristic resistance	$F_{Rk,fi}^{1)}$	[kN]	0.2	0.4	0.4	1.0	1.2
R 120	Characteristic resistance	$F_{Rk,fi}^{1)}$	[kN]	0.2	0.4	0.4	1.0	1.2
R 30 to R 120	Spacing	$s_{cr,fi}$	[mm]	130	180	210	170	200
		s_{min}	[mm]	55	60	80	100	120
	Edge distance	$c_{cr,fi}$	[mm]	65	90	105	85	100
		c_{min}	[mm]	95	95	95	135	165
If the fire attack is from more than one side, the edge distance shall be ≥ 300 mm.								

¹⁾ In absence of other national regulations the partial safety factor for resistance under fire exposure $\gamma_{M,fi} = 1.0$ is recommended

MKT Drop-in Anchor E

**Design method B,
Characteristic values of resistance,
Characteristic values under fire exposure in
concrete C20/25 to C50/60**

Annex 5

of European
Technical Approval

ETA-05/0116