

# Deutsches Institut für Bautechnik

Anstalt des öffentlichen Rechts

10829 Berlin, Kolonnenstraße 30 L  
Tel.: +49(0)30-78730-0  
Fax: +49(0)30-78730-320  
e-Mail: [dibt@dibt.de](mailto:dibt@dibt.de)



# DIBt

Mitglied der EOTA

## European Technical Approval

## ETA-03/0031

English translation prepared by DIBt

### Handelsbezeichnung

*Trade name*

MKT Einschlaganker E A4

*MKT Drop-In Anchor E A4*

### Zulassungsinhaber

*Holder of approval*

MKT

Metall-Kunststoff-Technik GmbH & Co. KG

Auf dem Immel 2

67685 Weilerbach

### Zulassungsgegenstand und Verwendungszweck

*Generic type and use  
of construction product*

Wegkontrolliert spreizender Dübel aus nichtrostendem  
Stahl in den Größen M 6, M 8x30, M 8x40, M 10, M 12,  
M 16 und M 20 zur Verankerung im ungerissenen Beton

*Deformation-controlled expansion anchor made of stainless steel of  
sizes M 6, M 8x30, M 8x40, M 10, M 12, M 16 and M 20 for use in  
non-cracked concrete*

### Geltungsdauer vom

*Validity from  
bis  
to*

12. November 2004

2. Oktober 2008

### Herstellwerk

*Manufacturing plant*

MKT

Metall-Kunststoff-Technik GmbH & Co. KG

Auf dem Immel 2

67685 Weilerbach

Diese europäische technische Zulassung ersetzt ETA-03/0031 mit Geltungsdauer vom 02.10.2003 bis 01.10.2008.  
This European Technical Approval replaces ETA-03/0031 with validity from 02.10.2003 to 01.10.2008.

Diese europäische  
technische Zulassung umfasst

*This European Technical Approval  
contains*

13 Seiten einschließlich 6 Anhänge

*13 pages including 6 annexes*



European Organisation for Technical Approvals

Europäische Organisation für Technische Zulassungen

## I LEGAL BASES AND GENERAL CONDITIONS

- 1 This European Technical Approval is issued by Deutsches Institut für Bautechnik in accordance with:
  - Council Directive 89/106/EEC of 21 December 1988 on the approximation of laws, regulations and administrative provisions of Member States relating to construction products<sup>1</sup>, amended by the Council Directive 93/68/EEC of 22 July 1993<sup>2</sup>;
  - *Gesetz über das In-Verkehr-Bringen von und den freien Warenverkehr mit Bauprodukten zur Umsetzung der Richtlinie 89/106/EWG des Rates vom 21. Dezember 1988 zur Angleichung der Rechts- und Verwaltungsvorschriften der Mitgliedstaaten über Bauprodukte und anderer Rechtsakte der Europäischen Gemeinschaften (Bauproduktengesetz - BauPG) vom 28. April 1998*<sup>3</sup>;
  - Common Procedural Rules for Requesting, Preparing and the Granting of European Technical Approvals set out in the Annex of Commission Decision 94/23/EC<sup>4</sup>;
  - Guideline for European Technical Approval of "Metal Anchors for Use in Concrete" ETAG 001, "Anchors in general", edition June 1997 and Part 4 "Deformation-controlled expansion anchors", edition July 1998.
- 2 Deutsches Institut für Bautechnik is authorized to check whether the provisions of this European Technical Approval are met. Checking may take place in the manufacturing plant. Nevertheless, the responsibility for the conformity of the products to the European Technical Approval and for their fitness for the intended use remains with the holder of the European Technical Approval.
- 3 This European Technical Approval is not to be transferred to manufacturers or agents of manufacturers other than those indicated on page 1, or manufacturing plants other than those indicated on page 1 of this European Technical Approval.
- 4 This European Technical Approval may be withdrawn by Deutsches Institut für Bautechnik, in particular after information by the Commission on the basis of Article 5 (1) of Council Directive 89/106/EEC.
- 5 Reproduction of this European Technical Approval including transmission by electronic means shall be in full. However, partial reproduction can be made with the written consent of the Deutsches Institut für Bautechnik. In this case partial reproduction has to be designated as such. Texts and drawings of advertising brochures shall not contradict or misuse the European Technical Approval.
- 6 The European Technical Approval is issued by the approval body in its official language. This version corresponds to the version circulated within EOTA. Translations into other languages have to be designated as such.

---

1 Official Journal of the European Communities N° L 40, 11.02.1989, p. 12

2 Official Journal of the European Communities N° L 220, 30.08.1993, p. 1

3 *Bundesgesetzblatt I, p. 812, zuletzt geändert durch Gesetz ('last amended by law on') vom 15.12.2001, Bundesgesetzblatt I, p. 3762*

4 Official Journal of the European Communities N° L 17, 20.01.1994, p. 34

## **II SPECIFIC CONDITIONS OF THE EUROPEAN TECHNICAL APPROVAL**

### **1 Definition of product and intended use**

#### **1.1 Definition of product**

The MKT Drop-in Anchor E A4 in the range of M6, M8 x 30, M8 x 40, M10, M12, M12 x 80, M16, M16 x 80 and M20 is an anchor made of stainless steel which is placed into a drilled hole and anchored by deformation-controlled expansion.

For the installed anchor see Figure given in Annex 1. The fixture shall be anchored with a fastening screw or threaded rod according to Annex 4.

#### **1.2 Intended use**

The anchor is intended to be used for anchorages for which requirements for mechanical resistance and stability and safety in use in the sense of the Essential Requirements 1 and 4 of Council Directive 89/106 EEC shall be fulfilled and failure of anchorages made with these products would cause risk to human life and/or lead to considerable economic consequences. The anchor is to be used only for anchorages subject to static or quasi-static loading in reinforced or unreinforced normal weight concrete of strength classes C20/25 at minimum and C50/60 at most according to EN 206-1:2000-12. It may be anchored in non-cracked concrete only.

The anchor may be used in structures subject to dry internal conditions and also in structures subject to external atmospheric exposure (including industrial and marine environment), or exposure in permanently damp internal conditions, if no particular aggressive conditions exist. Such particular aggressive conditions are e.g. permanent, alternating immersion in seawater or the splash zone of seawater, chloride atmosphere of indoor swimming pools or atmosphere with extreme chemical pollution (e.g. in desulphurization plants or road tunnels where de-icing materials are used).

The provisions made in this European Technical Approval are based on an assumed intended working life of the anchor of 50 years. The indications given on the working life cannot be interpreted as a guarantee given by the producer, but are to be regarded only as a means for choosing the right products in relation to the expected economically reasonable working life of the works.

### **2 Characteristics of product and methods of verification**

#### **2.1 Characteristics of product**

The anchor corresponds to the drawings and provisions given in Annex 2. The characteristic material values, dimensions and tolerances of the anchor not indicated in Annex 2 shall correspond to the respective values laid down in the technical documentation<sup>5</sup> of this European Technical Approval.

The fastening screw or threaded rod shall correspond at least to the strength class A4-70 according to EN ISO 3506.

The characteristic anchor values for the design of anchorages are given in Annexes 4 to 6.

---

<sup>5</sup> The technical documentation of this European Technical Approval is deposited at the Deutsches Institut für Bautechnik and, as far as relevant for the tasks of the approved bodies involved in the attestation of conformity procedure, is handed over to the approved bodies.

Each anchor is marked with the identifying mark of the producer, the trade name, the size of thread and the letter "A4" according to Annex 2.

In addition, the expansion sleeve for anchor size M8 x 40 is marked on the top of the sleeve. The anchor shall only be packaged and supplied as a complete unit.

## **2.2 Methods of verification**

The assessment of fitness of the anchor for the intended use in relation to the requirements for mechanical resistance and stability and safety in use in the sense of the Essential Requirements 1 and 4 has been made in accordance with the "Guideline for European Technical Approval of Metal Anchors for Use in Concrete", Part 1 "Anchors in general" and Part 4 "Deformation-controlled expansion anchors" on the basis of Option 7.

## **3 Evaluation of Conformity and CE marking**

### **3.1 Attestation of Conformity system**

The system of attestation of conformity 2 (i) (referred to as System 1) according to Council Directive 89/106/EEC Annex III laid down by the European Commission provides:

- a) tasks for the manufacturer:
  - (1) factory production control,
  - (2) further testing of samples taken at the factory by the manufacturer in accordance with a control plan.
- b) tasks for the approved body:
  - (3) initial type-testing of the product,
  - (4) initial inspection of factory and of factory production control,
  - (5) continuous surveillance, assessment and approval of factory production control.

### **3.2 Responsibilities**

#### **3.2.1 Tasks of the manufacturer; factory production control**

The manufacturer has a factory production control system in the plant and exercises permanent internal control of production. All the elements, requirements and provisions adopted by the manufacturer are documented in a systematic manner in the form of written policies and procedures. The production control system ensures that the product is in conformity with the European Technical Approval.

The manufacturer shall only use raw materials supplied with the relevant inspection documents as laid down in the control plan<sup>6</sup>. The incoming raw materials shall be subject to controls and tests by the manufacturer before acceptance. Check of materials shall include control of the inspection documents presented by suppliers (comparison with nominal values) by verifying dimensions and determining material properties, e.g. tensile strength, hardness, surface finish.

The manufactured components of the anchor shall be subjected to the following tests:

- Dimensions of component parts:
  - cone (diameter, length, angle of the tapering);
  - expansion sleeve (length, thickness, diameters);
  - setting tool (length and diameter of pin)

---

<sup>6</sup> The control plan has been deposited at the Deutsches Institut für Bautechnik and is handed over only to the approved bodies involved in the conformity attestation procedure.

- Material properties:
  - cone (hardness);
  - expansion sleeve (hardness, tensile strength and yield limit of raw material);
- Coating of the cone
- Visual control of correct assemblage and of completeness of the anchor.

The frequency of controls and tests conducted during production and on the assembled anchor is laid down in the control plan taking account of the automated manufacturing process of the anchor.

The results of factory production control are recorded and evaluated. The records include at least the following information:

- designation of the product, basic material and components;
- type of control or testing;
- date of manufacture of the product and date of testing of the product or basic material and components;
- result of control and testing and, if appropriate, comparison with requirements;
- signature of person responsible for factory production control.

The records shall be presented to the inspection body involved in the continuous surveillance. On request they shall be presented to the Deutsches Institut für Bautechnik.

Details of the extent, nature and frequency of testing and controls to be performed within the factory production control shall correspond to the control plan<sup>6</sup> which is part of the technical documentation of this European Technical Approval.

### 3.2.2 Tasks of approved bodies

#### 3.2.2.1 Initial type-testing of the product

For initial type-testing the results of the tests performed as part of the assessment for the European Technical Approval shall be used unless there are changes in the production line or plant. In such cases the necessary initial type-testing has to be agreed between the Deutsches Institut für Bautechnik and the approved bodies involved.

#### 3.2.2.2 Initial inspection of factory and of factory production control

The approved body shall ascertain that, in accordance with the control plan, the factory, in particular the staff and equipment, and the factory production control are suitable to ensure a continuous and orderly manufacturing of the anchor with the specifications mentioned in 2.1 as well as in the Annexes to the European Technical Approval, in accordance with the control plan.

#### 3.2.2.3 Continuous surveillance

The approved body shall visit the factory at least once a year for surveillance. It has to be verified that the system of factory production control and the specified automated manufacturing process are maintained taking account of the control plan.

Continuous surveillance and assessment of factory production control have to be performed according to the control plan.

The results of product certification and continuous surveillance shall be made available on demand by the certification body or inspection body, respectively, to the Deutsches Institut für Bautechnik.

In cases where the provisions of the European Technical Approval and the control plan are no longer fulfilled the conformity certificate shall be withdrawn.

### **3.3 CE marking**

The CE marking shall be affixed on each packaging of anchors. The symbol "CE" shall be accompanied by the following information:

- identification number of the certification body;
- name or identifying mark of holder of approval and manufacturing plant;
- the last two digits of the year in which the CE marking was affixed;
- number of the EC certificate of conformity;
- number of the European Technical Approval;
- use category (ETAG 001-1 Option 7);
- size.

## **4 Assumptions under which the fitness of the product for the intended use was favourably assessed**

### **4.1 Manufacturing**

The anchor is manufactured in accordance with the provisions of the European Technical Approval using the automated manufacturing process as identified in the inspection of the plant by the Deutsches Institut für Bautechnik and the approved body and laid down in the technical documentation.

### **4.2 Installation**

#### **4.2.1 Design of anchorages**

The fitness of the anchor for the intended use is given under the following conditions:

The anchorages are designed in accordance with the "Guideline for European Technical Approval of Metal Anchors for Use in Concrete", Annex C, Method A, for deformation controlled expansion anchors under the responsibility of an engineer experienced in anchorages and concrete work.

Verifiable calculation notes and drawings are prepared taking account of the loads to be anchored.

The position of the anchor is indicated on the design drawings (e.g. position of the anchor relative to reinforcement or to supports).

The minimum strength class and the minimum screwing depth of the fastening screw or the threaded rod for installation of the fixture shall be met the requirements according to Annex 4. The length of the fastening screw shall be defined according to the requirements given in Annex 4, taking into account the available thread length, the minimum screwing depth, the thickness of fixture and tolerances of member and fixture.

#### **4.2.2 Installation of anchors**

The fitness for use of the anchor can only be assumed if the anchor is installed as follows:

- Anchor installation carried out by appropriately qualified personnel and under the supervision of the person responsible for technical matters of the site.
- Use of the anchor only as supplied by the manufacturer without exchanging the components of an anchor.
- Anchor installation in accordance with the manufacturer's specifications and drawings and using the appropriate tools;
- Checks before placing the anchor to ensure that the strength class of the concrete in which the anchor is to be placed is in the range given and is not lower than that of the concrete to which the characteristic loads apply.
- Check of concrete being well compacted, e.g. without significant voids.
- Clearing of the hole of drilling dust.

- Anchor installation such that the effective setting depth is complied with. This compliance is ensured, if the anchor is completely set into the drill hole.
- Anchor expansion by impact on the cone using the manual setting tools given in Annex 3. The anchor is properly set if the stop of the setting tool reaches the expansion sleeve. The setting tool for marking leaves a visible mark on the sleeve as illustrated in Annex 3.
- Keeping of the edge distance and spacing to the specified values without minus tolerances.
- Positioning of the drill holes without damaging the reinforcement.
- In case of aborted hole: new drilling at a minimum distance away of twice the depth of the aborted hole or smaller distance if the aborted drill hole is filled with high strength mortar and if under shear or oblique tension load it is not in the direction of load application.
- The fastening screw or threaded rod shall correspond to the requirements given in Annex 4.
- Fixing the screw with the recommended torque moment given in Annex 4 using a calibrated torque wrench.

#### 4.2.3 Responsibility of the manufacturer

It is in the responsibility of the manufacturer to ensure that the information on the specific conditions according to 1 and 2 including Annexes referred to and 4.2.1 and 4.2.2 is given to those who are concerned. This information may be made by reproduction of the respective parts of the European Technical Approval. In addition all installation data shall be shown clearly on the package and/or on an enclosed instruction sheet, preferably using illustration(s).

The minimum data required are:

- drill bit diameter,
- thread diameter,
- minimum effective anchorage depth,
- available thread length and minimum screwing depth of the fastening screw
- minimum strength class of the fastening screw or threaded rod accord. to EN ISO 3506
- minimum hole depth,
- torque moment,
- information on the installation procedure, including cleaning of the hole, preferably by means of an illustration,
- reference to any special installation equipment needed,
- identification of the manufacturing batch.

All data shall be presented in a clear and explicit form.

Dipl.-Ing. Jasch

*Beglaubigt:*  
Lange

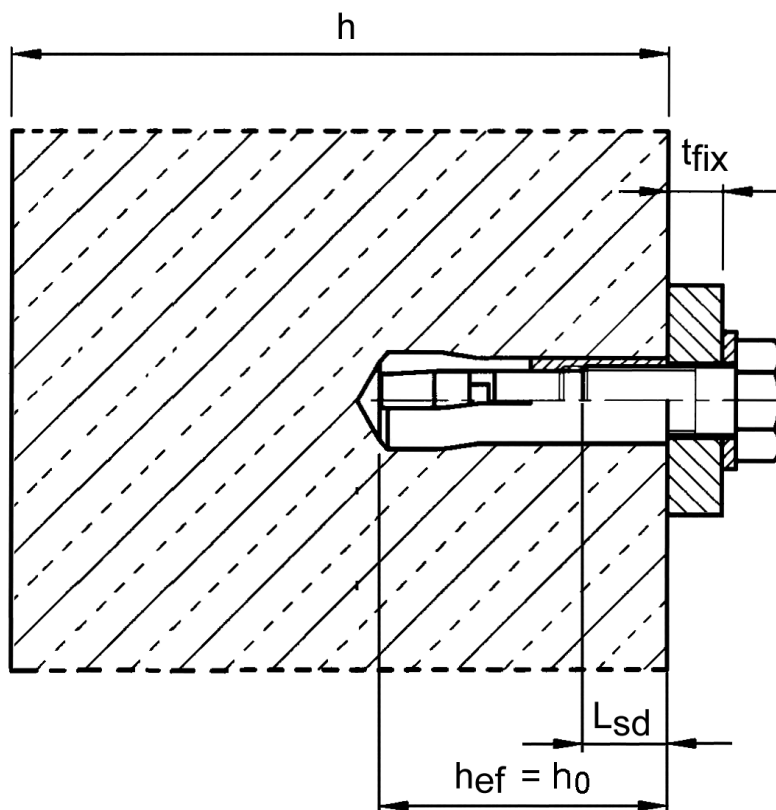
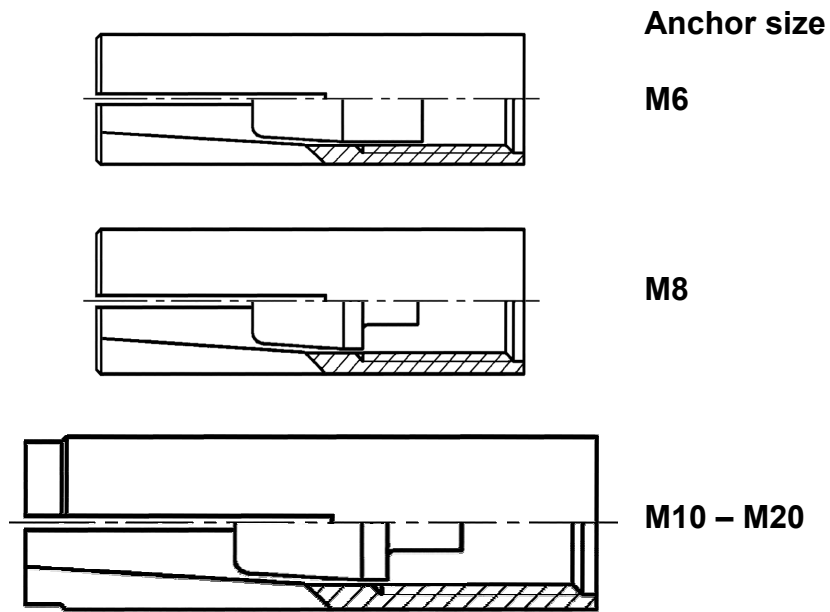

**MKT Drop-in Anchor E A4**



**Product and intended use**

**Annex 1**

of European  
 Technical Approval

**ETA-03/0031**

**Expansion sleeve**

Marking: e.g.:  E M8 A4  
 Identifying mark of manufacturing plant   
 Anchor identity E  
 Size of thread M 8  
 Stainless steel A4

Anchor size M8x40 A4:

additional marking d, visible after installation

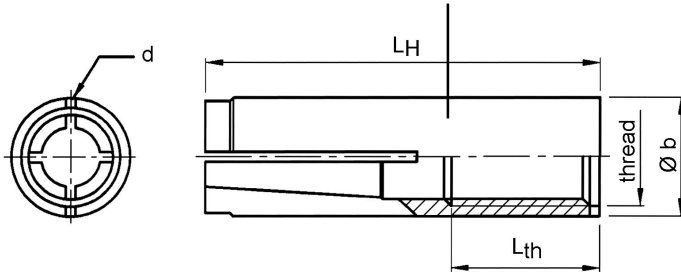

**Cone  
Anchor size M6**

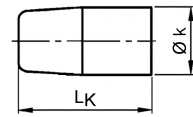

**Anchor sizes M8–M20**

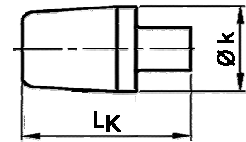

**Table 1: Dimensions**

Anchor size	expansion sleeve				cone	
	thread	Ø b	L <sub>H</sub>	L <sub>th</sub>	Ø k	L <sub>k</sub>
M6	M6	8	30	13	5.0	13
M8	M8	10	30	13	6.5	12
M8x40	M8	10	40	20		
M10	M10	12	40	15	8.2	16
M12	M12	15	50	18	10.3	20
M12x80	M12	15	80	45		
M16	M16	19.7	65	23		
M16x80	M16	19.7	80	38	13.8	29
M20	M20	24.7	80	34		

**Table 2: Designation of anchor parts and materials**

Part	Designation of anchor parts	Materials,
1	Expansion sleeve	Stainless steel, 1.4401, 1.4404, 1.4571, EN 10088
2	Cone	Stainless steel, 1.4401, 1.4404, 1.4571, EN 10088

**MKT Drop-in Anchor E A4**

**Dimensions and Materials**

**Annex 2**

of European  
Technical Approval

**ETA-03/0031**

**Setting tool for marking**

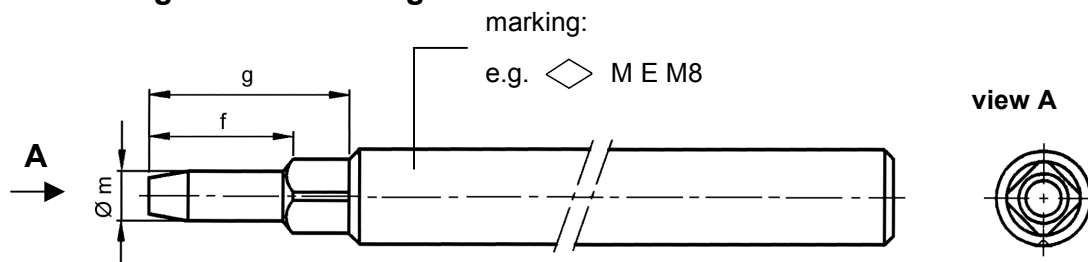

**Verification of correct installation with setting tool for marking**

The setting tool leaves a visible impression after correct installation.

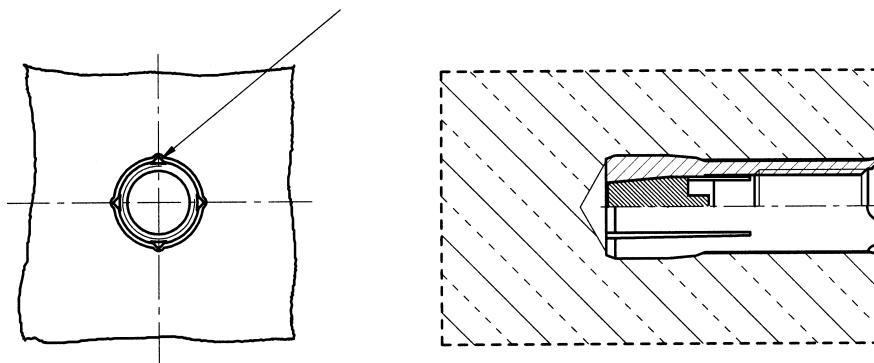

**Setting tool**

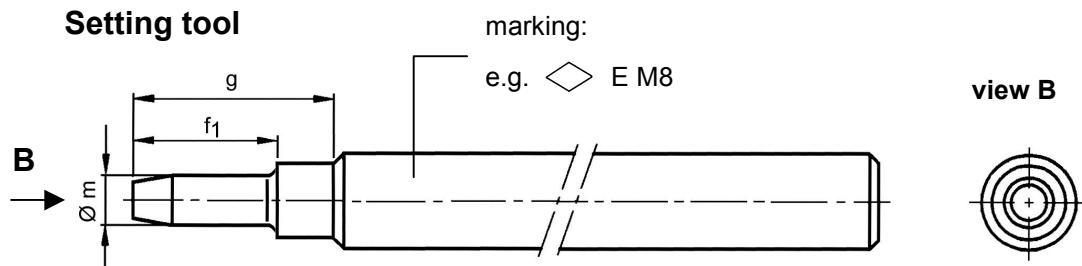

**Table 3: Dimensions of setting tools**

Anchor size	Ø m	f	f <sub>1</sub>	g
M6	4.9	-	17	27
M8	6.4	18.2	18	28
M8x40	6.4	28.2	28	38
M10	8.0	24.2	24	34
M12	10.0	30.4	30	40
M12x80	10.0	60.4	60	70
M16	13.5	36.6	36	46
M16x80	13.5	51.6	51	61
M20	16.5	50.7	50	60

**MKT Drop-in Anchor E A4**

**Dimensions of setting tools and verification of correct installation**

**Annex 3**

of European  
Technical Approval

**ETA-03/0031**

**Table 4: Installation parameters**

Anchor size		M6	M8	M8x40	M10	M12	M12x80	M16	M16x80	M20
Depth of drill hole	$h_0$ [mm]	30	30	40	40	50	80	65	80	80
Drill hole diameter	$d_{0=}$ [mm]	8	10	10	12	15	15	20	20	25
Cutting diameter of drill bit	$d_{cut} \leq$ [mm]	8.45	10.45	10.45	12.5	15.5	15.5	20.55	20.55	25.55
Recommended setting torque	$T_{inst} =$ [Nm]	4	8	8	15	35	35	60	60	120
Diameter of clearance hole in the fixture	$d_f \leq$ [mm]	7	9	9	12	14	14	18	18	22
Available thread length	$L_{th}$ [mm]	13	13	20	15	18	45	23	38	34
Minimum screwing depth	$L_{sdmin}$ [mm]	7	9	9	11	13	13	18	18	22
Minimum thickness of member	$h_{min}$ [mm]	100	100	100	130	140	140	160	160	250
Minimum spacing and Edge distance	$s_{min}$ [mm]	50	60	80	100	120	120	150	150	160
	$c_{min}$ [mm]	80	95	95	135	165	165	200	200	260

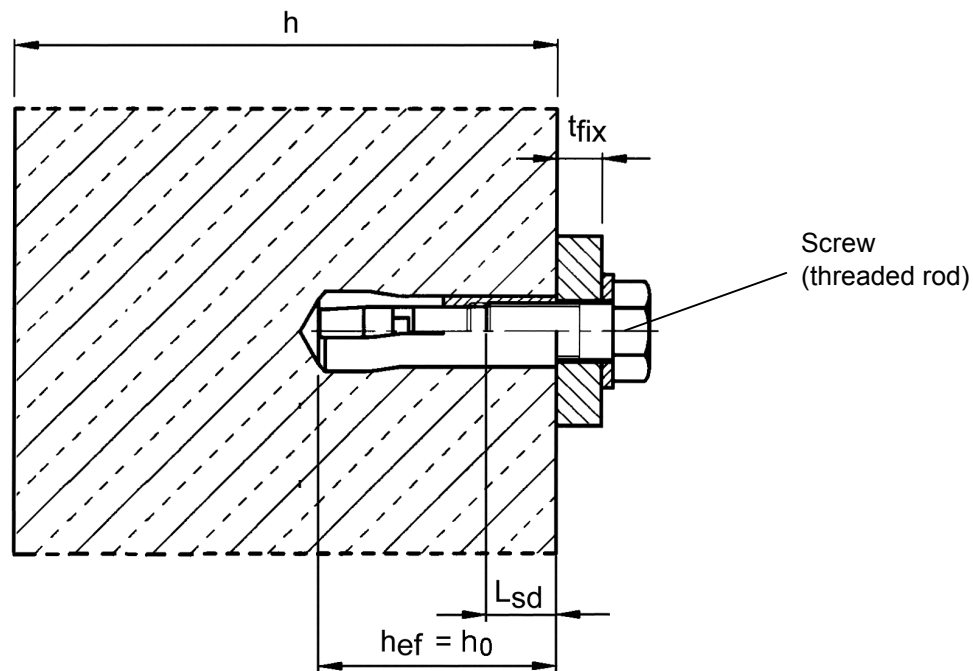
**Requirements for the fastening screw or threaded rod:**

- Minimum strength class A4-70 acc. ISO 3506;
- Minimum screwing depth  $L_{sdmin}$  see Table 4;
- The length of the fastening screw shall be determined depending on thickness of fixture  $t_{fix}$ , admissible tolerances, available thread length  $L_{th}$  (= maximum screwing depth) and minimum screwing depth  $L_{sdmin}$ ;

**MKT Drop-in Anchor E A4****Installation parameters****Annex 4**of European  
Technical Approval**ETA-03/0031**

**Table 5: Characteristic values of resistance to tension loads of design method A**

Anchor size			M6 <sup>1)</sup>	M8 <sup>1)</sup>	M8x40	M10	M12 M12x80	M16 M16x80	M20
<b>Steel failure</b>									
Characteristic resistance	$N_{Rk,s}$	[kN]	14	23		29	52	84	133
Partial safety factor	$\gamma_{MS}$ <sup>3)</sup>	-	1.87						
<b>Pull-out failure</b>									
Characteristic resistance in non-cracked concrete	$N_{Rk,p}$ C20/25	[kN]	2)	2)	9	2)	2)	2)	2)
Increasing factors for $N_{Rk,p}$ for non-cracked concrete $\psi_C$	C30/37		1.15	1.22					
	C40/50		1.24	1.41					
	C50/60		1.30	1.55					
Partial safety factor	$\gamma_{Mp}$ <sup>3)</sup>		1.8 <sup>4)</sup>			1.5 <sup>4)</sup>			
<b>Concrete cone failure and splitting</b>									
Effective anchorage depth	$h_{ef} = h_0$	[mm]	30	30	40	40	50	65	80
Spacing	$s_{cr,N}$	[mm]	3 $h_{ef}$						
	$s_{cr,Sp}$	[mm]	160	190	190	270	330	400	520
Edge distance	$c_{cr,N}$	[mm]	1,5 $h_{ef}$						
	$c_{cr,Sp}$	[mm]	80	95	95	135	165	200	260
Partial safety factor	$\gamma_{Mc} = \gamma_{M,Sp}$ <sup>3)</sup>		1.8 <sup>4)</sup>			1.5 <sup>4)</sup>			

<sup>1)</sup> Use restricted to anchoring of structural components statically indetermined

<sup>2)</sup> pull-out failure mode not decisive

<sup>3)</sup> In absence of other national regulations

<sup>4)</sup> The partial safety factor  $\gamma_2$  is included

**Table 6: Displacements under tension loads**

Anchor size			M6	M8	M8x40	M10	M12	M16	M20
Tension load in non-cracked concrete	N	[kN]	3.3	3.3	3.6	6.1	8.5	12.6	17.2
Displacement	$\delta_{N0}$	[mm]	0.12						
	$\delta_{N\infty}$	[mm]	0.24						

**MKT Drop-in Anchor E A4**

**Design method A,  
Characteristic values for tension loads,  
Displacements**

**Annex 5**

of European  
Technical Approval

**ETA-03/0031**

**Table 7: Characteristic values of resistance to shear loads of design method A**

Anchor size			M6	M8	M8x40	M10	M12 M12x80	M16 M16x80	M20
<b>Steel failure without lever arm</b>									
Characteristic resistance (A4-70)	$V_{Rk,s}$	[kN]	7	10		13	26	42	67
Partial safety factor	$\gamma_{Ms}^{1)}$	-	1.56						
<b>Steel failure with lever arm</b>									
Characteristic resistance (A4-70)	$M_{Rk,s}^0$	[Nm]	11	26		52	92	233	454
Partial safety factor	$\gamma_{Ms}^{1)}$	-	1.56						
Characteristic resistance (A4-80)	$M_{Rk,s}^0$	[Nm]	12	30		60	105	266	519
Partial safety factor	$\gamma_{Ms}^{1)}$	-	1.33						
<b>Concrete pryout failure</b>									
Factor in equation (5.6) ETAG Annex C, 5.2.3.3	k		1.0	1.7				2.0	2.0
Partial safety factor	$\gamma_{Mcp}^{1)}$		1.5 <sup>2)</sup>						
<b>Concrete edge failure</b>									
Effective length of anchor under shear loading	$l_f$	[mm]	30	30	40	40	50	65	80
Outside diameter of anchor	$d_{nom}$	[mm]	8	10	10	12	15	20	25
Partial safety factor	$\gamma_{Mc}^{1)}$		1.5 <sup>2)</sup>						

<sup>1)</sup> In absence of other national regulations

<sup>2)</sup> The partial safety factor  $\gamma_2 = 1.0$  is included

**Table 8: Displacements under shear loads**

Anchor size			M6	M8	M8x40	M10	M12 M12x80	M16 M16x80	M20
Shear load in non-cracked concrete	V	[kN]	3.5	5.2	5.2	6.5	11.5	19.2	30.4
Displacement	$\delta_{V0}$	[mm]	1.9	1.1	0.7	1.0	1.7	2.4	2.6
	$\delta_{V\infty}$	[mm]	2.8	1.6	1.0	1.5	2.6	3.6	3.8

**MKT Drop-in Anchor E A4**

**Design method A,  
Characteristic values for shear loading  
Displacements**

**Annex 6**

of European  
Technical Approval

**ETA-03/0031**